

Government Gazette Staatskoerant

REPUBLIC OF SOUTH AFRICA
REPUBLIEK VAN SUID-AFRIKA

Vol. 512

Pretoria, 29 February
Februarie 2008

No. 30805

For purposes of reference, all Proclamations, Government Notices, General Notices and Board Notices published are included in the following table of contents which thus forms a weekly index. Let yourself be guided by the Gazette numbers in the righthand column:

CONTENTS and weekly Index

No.	Page No.	Gazette No.
GOVERNMENT AND GENERAL NOTICES		
Agriculture, Department of		
<i>Government Notices</i>		
R. 186		
Agricultural Product Standards Act (119/1990): Regulations: Grading, packing and marking of wheat products intended for sale in the Republic of South Africa.....	3	30782
R. 191		
Animal Identification Act (6/2002): Regulations: Amendment.....	27	30782
214		
Plant Breeder's Rights Act (15/1976): Applications for plant breeders' rights.....	3	30791
Department of Communications		
<i>General Notice</i>		
279		
Electronic Communications Act (36/2005): Notice inviting comments on proposed guidelines for rapid deployment of electronic communications facilities	3	30800
Defence, Department of		
<i>General Notices</i>		
280		
Explanatory summary of the Castle Management Repeal Bill.....	3	30803
281		
Explanatory summary of the Defence Amendment Bill.....	4	30803
Education, Department of		
<i>Government Notice</i>		
200		
National Education Policy Act (27/1996): 2009 School calendar for public schools	3	30787
<i>General Notice</i>		
278		
National Schools Pledge: Call for comments on the Draft National Schools Pledge	3	30801
Environmental Affairs and Tourism, Department of		
<i>Government Notices</i>		
231		
National Environmental Management: Protected Areas Act (57/2003): Addo Elephant National Park: Exclusion of land from the park	7	30805
232		
do.: Intention to declare certain land situated in the Bredasdorp Registration Division, Western Cape Area as part of the Agulhas National Park.....	8	30805
233		
do.: Intention to declare certain land situated in the KQ Registration Division, Limpopo Province as part of the Marakele National Park.....	10	30805
234		
do.: Intention to declare certain land situated in the MS Registration Division, Limpopo Province as part of the Mapungubwe National Park.....	13	30805
235		
do.: Intention to declare certain land situated in the Namaqualand Registration Division, Northern Cape Province as part of the Namaqua National Park.....	15	30805

Alle Proklamasies, Goewermentskennisgewings, Algemene Kennisgewings en Raadskennisgewings gepubliseer, word vir verwysingsdoeleindes in die volgende Inhoudsopgawe ingesluit wat dus 'n weeklikse indeks voorstel. Laat self deur die Koerantnommers in die regterhandse kolom lei:

INHOUD en weeklikse Indeks

No.	Bladsy No.	Koerant No.
GOEWERMENTS- EN ALGEMENE KENNISGEWINGS		
Arbeid, Departement van		
<i>Algemene Kennisgewings</i>		
300		
Labour Relations Act (66/1995): Intention to cancel the registration of an employers' organisation: Security Industry Association of South Africa (SIASA)	79	30805
302		
Labour Relations Act (66/1995): Intention to cancel the registration of a trade union: South African Food and Allied Trade Union (SAFATU)	81	30805
303		
do.: Registration of a trade union: South African Emergency Personnel's Union (SAEPU).....	90	30805
304		
do.: Notice published by the Essential Services Committee	82	30805
Behuising, Departement van		
<i>Goewermentskennisgewing</i>		
R. 192		
Housing Consumer Protection Measures Act (95/1998): National Home Builders Registration Council: Home Builder Grading System	31	30782
Binnelandse Sake, Departement van		
<i>Goewermentskennisgewings</i>		
226		
Births and Deaths Registration Act (51/1992): Rectification Notice: Assumption of another surname	22	30805
227		
do.: do.: do	23	30805
228		
do.: Alteration of surnames	25	30805
229		
do.: do	35	30805
230		
do.: Alteration of forenames	36	30805
Finansies, Departement van		
<i>Algemene Kennisgewing</i>		
305		
Short-term Insurance Act (53/1998): Financial Services Board: Notice on proposed variation of Policyholder Protection Rules (Short-term Insurance), 2004	83	30805
Gesondheid, Departement van		
<i>Goewermentskennisgewings</i>		
R. 194		
Nursing Act (33/2005): Notice regarding the creation of categories of practitioners in terms of the Act	30	30782
R. 195		
do.: South African Nursing Council: Regulations: Particulars to be furnished to the Council for keeping of the register for nursing practitioners, the manner of effecting alterations to the register, and certificates that may be issued by the Council	3	30786

No.	Page No.	Gazette No.	No.	Bladsy No.	Koerant No.
236			Grondsake, Departement van		
National Environmental Management: Intention to declare certain land situated in the Kenhardt Registration Division, Northern Cape as part of the Augrabies Falls National Park.....			<i>Algemene Kennisgewings</i>		
	17	30805	282		
237			292	2	30804
do.: Intention to declare certain land situated in the Calvinia, Ceres and Sutherland Divisions, Northern Cape Area as part of the Tankwa-Karoo National Park.....			293	62	30805
	19	30805	294	63	30805
Finance, Department of			295	68	30805
<i>General Notice</i>			296	70	30805
305			297	72	30805
Short-term Insurance Act (53/1998): Financial Services Board: Notice on proposed variation of Policyholder Protection Rules (Short-term Insurance), 2004			298	74	30805
	83	30805	299	77	30805
Health, Department of			301	78	30805
<i>Government Notices</i>			Handel en Nywerheid, Departement van		
R. 194			<i>Goewermentskennisgewings</i>		
Nursing Act (33/2005): Notice regarding the creation of categories of practitioners in terms of the Act.....			R. 193	37	30782
	30	30782	224	46	30805
R. 195			225	59	30805
do.: South African Nursing Council: Regulations: Particulars to be furnished to the Council for keeping of the register for nursing practitioners, the manner of effecting alterations to the register, and certificates that may be issued by the Council			<i>Algemene Kennisgewings</i>		
	3	30786	247	3	30768
Home Affairs, Department of			248	5	30768
<i>Government Notices</i>			249	7	30768
226			250	8	30768
Births and Deaths Registration Act (51/1992): Rectification Notice: Assumption of another surname			283	3	30809
	22	30805	Maatskappywet (61/1973).....		
227			Deregistrasie van Maatskappye (A-Lys).....		
do.: do.			Deregistrasie van Maatskappye (B-Lys).....		
	23	30805	Deregistrasie van Buitelandse Maatskappye (A-Lys).....		
228			Deregistrasie van Buitelandse Maatskappye (B-Lys).....		
do.: Alteration of surnames			284	9	
	25	30805	Wet op Beslote Korporasies (69/1984): .		
229			Finale Deregistrasie van Beslote Korporasies.....		
do.: do.			285	11	30809
	35	30805	286	86	30805
230			287	87	30805
do.: Alteration of forenames			288	88	30805
	36	30805	289	88	30805
Housing, Department of			290	89	30805
<i>Government Notice</i>			291	60	30805
R. 192			Competition Act (89/1998): Competition Commission: Application for an exemption.....		
Housing Consumer Protection Measures Act (95/1998): National Home Builders Registration Council: Home Builder Grading System					
	31	30782			
Independent Communications Authority of South Africa					
<i>General Notice</i>					
276					
Electronic Communications Act (36/2005): Application for the amendment of a community sound broadcasting licence: Campus Bay FM					
	3	30798			
Justice and Constitutional Development, Department of					
<i>Government Notices</i>					
218					
Small Claims Courts Act (61/1984): Establishment of a small claims court for the area of Sekgosese					
	42	30805			
219					
do.: Establishment of a small claims court for the area of Musina.....					
	44	30805			
277					
Publication of explanatory summary of the Renaming of High Courts, Bill 2008 .					
	3	30799			

No.	Page No.	Gazette No.	No.	Bladsy No.	Koerant No.
Labour, Department of			Justisie en Staatkundige Ontwikkeling, Departement van		
<i>General Notices</i>			<i>Goewermentskennisgewings</i>		
300			218		
Labour Relations Act (66/1995): Intention to cancel the registration of an employers' organisation: Security Industry Association of South Africa (SIASA).....	79	30805	Wet op Howe vir Klein Eise (61/1984): Instelling van 'n hof vir klein eise vir die gebied Sekgosese.....	43	30805
302			219		
Labour Relations Act (66/1995): Intention to cancel the registration of a trade union: South African Food and Allied Trade Union (SAFATU).....	81	30805	do.: Intrekking van 'n hof vir klein eise vir die gebied Musina.....	45	30805
303			277		
do.: Registration of a trade union: South African Emergency Personnel's Union (SAEPU).....	90	30805	Publikasie van verduidelikende opsomming van die Wetsontwerp op die Herbenaming van die Hoë Howe, 2008..	4	30799
304			Kommunikasiewese, Departement van		
do.: Notice published by the Essential Services Committee.....	82	30805	<i>Algemene Kennisgewing</i>		
Land Affairs, Department of			279 Electronic Communications Act (36/2005): Notice inviting comments on proposed guidelines for rapid deployment of electronic communications facilities.....		
<i>General Notices</i>				3	30800
282			Landbou, Departement van		
Publication of Provision of Land and Assistance Amendment Bill: For general comment.....	2	30804	<i>Goewermentskennisgewings</i>		
292			R. 186		
Restitution of Land Rights Act (22/1994): Claim for the restitution of land rights: Erf 8544, Parow.....	62	30805	Wet op Landbouprodukstandaarde (119/1990): Regulasies: Gradering, verpakking en merk van koringprodukte bestem vir verkoop in die Republiek van Suid-Afrika.....	15	30782
293			R. 191		
do.: do.: Remaining Extent of Portion 1, farm Kingston Vale 125 JU.....	63	30805	Wet op die Identifikasie van Diere (6/2002): Regulasies: Wysiging.....	28	30782
294			214		
do.: do.: Portion 33, farm Klipportjie 32 IS.....	68	30805	Wet op Planttelersregte (15/1976): Aansoek om planttelersregte.....	3	30791
295			Omgewingsake en Toerisme, Departement van		
do.: do.: Remaining Extent of Portion 11, farm Braakfontein 310 JR.....	70	30805	<i>Goewermentskennisgewings</i>		
296			231		
do.: do.: Remaining Extent of the farm Bankfontein 216 IR.....	72	30805	National Environmental Management: Protected Areas Act (57/2003): Addo Elephant National Park: Exclusion of land from the park.....	7	30805
297			232		
do.: do.: Remaining Extent of Portion 2, farm Witklipbank 202 IR.....	74	30805	do.: Intention to declare certain land situated in the Bredasdorp Registration Division, Western Cape Area as part of the Agulhas National Park.....	8	30805
298			233		
do.: do.: Erf 21692 and Erven 35232 and 35231, Kensington and Athlone.....	77	30805	do.: Intention to declare certain land situated in the KQ Registration Division, Limpopo Province as part of the Marakele National Park.....	10	30805
299			234		
do.: do.: Erf 11865, Woodstock.....	78	30805	do.: Intention to declare certain land situated in the MS Registration Division, Limpopo Province as part of the Mapungubwe National Park.....	13	30805
301			235		
Restitution of Land Rights Act (22/1994): Claim for the restitution of land rights: Erf 1012, Cape Town.....	80	30805	do.: Intention to declare certain land situated in the Namaqualand Registration Division, Northern Cape Province as part of the Namaqua National Park.....	15	30805
South African Qualifications Authority			236		
<i>Government Notices</i>			do.: Intention to declare certain land situated in the Kenhardt Registration Division, Northern Cape as part of the Augrabies Falls National Park.....	17	30805
201			237		
Directorate for Standards Setting and Development: Intention to re-register the Standards Generating Body (SGB) for Engineering.....	3	30788	do.: Intention to declare certain land situated in the Calvinia, Ceres and Sutherland Divisions, Northern Cape Area as part of the Tankwa-Karoo National Park.....	19	30805
202			Onafhanklike Kommunikasie Owerheid van Suid-Afrika		
do.: Intention to re-register the Standards Generating Body (SGB) for Manufacturing and Assembly Processes (MAP).....	6	30788	<i>Algemene Kennisgewing</i>		
203			276		
do.: Intention to re-register the Standards Generating Body (SGB) for Vehicle Maintenance.....	8	30788	Electronic Communications Act (36/2005): Application for the amendment of a community sound broadcasting licence: Campus Bay FM.....	3	30798
204					
do.: Intention to re-register the Standards Generating Body (SGB) for Air-conditioning, Refrigeration and Ventilation.....	12	30788			
205					
do.: Intention to re-register the Standards Generating Body (SGB) Clothing, Textile, Footwear and Leather.....	15	30788			
206					
do.: Intention to re-register the Standards Generating Body (SGB) for Pulp and Paper.....	19	30788			
207					
do.: Intention to re-register the Standards Generating Body (SGB) for Mining and Minerals.....	23	30788			
208					
National Standards Bodies Regulations: Standards Generating Body (SGB) for Art, Craft and Design.....	31	30788			
209					
do.: Task team for School Business Management.....	49	30788			

No.	Page No.	Gazette No.	No.	Bladsy No.	Koerant No.
210					
211	73	30788			
212	206	30788			
	253	30788			
South African Revenue Service					
<i>Government Notices</i>					
214	3	30794			
215	3	30795			
216	3	30796			
<i>General Notices</i>					
273	3	30793			
Trade and Industry, Department of					
<i>Government Notices</i>					
R. 193	37	30782			
224	46	30805			
225	59	30805			
<i>General Notices</i>					
247	3	30768			
248	5	30768			
249	7	30768			
250	8	30768			
283	3	30809			
	4				
	5				
	8				
	9				
284	10				
	11	30809			
285	16	30809			
286	86	30805			
287	86	30805			
288	87	30805			
289	88	30805			
290	89	30805			
Onderwys, Departement van					
<i>Goewermentskennisgewing</i>					
200				3	30787
<i>Algemene Kennisgewing</i>					
278				3	30801
Suid-Afrikaanse Inkomstediens					
<i>Goewermentskennisgewings</i>					
214				3	30794
215				5	30795
216				6	30796
<i>Algemene Kennisgewing</i>					
273				3	30793
Suid-Afrikaanse Kwalifikasie Owerheid					
<i>Goewermentskennisgewings</i>					
201				3	30788
202				6	30788
203				8	30788
204				12	30788
205				15	30788
206				19	30788
207				23	30788
208				31	30788
209				49	30788
210				73	30788
211				206	30788
212				253	30788
Weermag, Departement van					
<i>Algemene Kennisgewings</i>					
280				3	30803

<i>No.</i>	<i>Page No.</i>	<i>Gazette No.</i>	<i>No.</i>	<i>Bladsy No.</i>	<i>Koerant No.</i>
291			281		
Competition Act (89/1998): Competition Commission: Application for an exemption	60	30805	Explanatory summary of the Defence Amendment Bill	4	30803
BOARD NOTICES			RAADSKENNISGEWINGS		
14			14		
Medical Schemes Act (131/1998): Council for Medical Schemes: Medical schemes registered	2	30789	Wet op Mediese Skemas (131/1998): Raad van Mediese Skemas: Mediese skemas geregistreer	2	30789
15			15		
Financial Advisory and Intermediary Services Act (37/2002): Financial Services Board: Exemption of authorised financial services providers as regards representatives	2	30810	Financial Advisory and Intermediary Services Act (37/2002): Financial Services Board: Exemption of authorised financial services providers as regards representatives	2	30810

GOVERNMENT NOTICES GOEWERMENTSKENNISGEWINGS

DEPARTMENT OF ENVIRONMENTAL AFFAIRS AND TOURISM DEPARTEMENT VAN OMGEWINGSAKE EN TOERISME

No. 231

29 February 2008

ADDO ELEPHANT NATIONAL PARK: EXCLUSION OF LAND FROM THE PARK IN TERMS OF THE NATIONAL ENVIRONMENTAL MANAGEMENT: PROTECTED AREAS ACT, 2003 (ACT NO. 57 OF 2003)

I, Marthinus Christoffel Johannes van Schalkwyk, Minister of Environmental Affairs and Tourism, hereby –

- (a) under section 21(1)(a) of the National Environmental Management: Protected Areas Act, 2003 (Act No. 57 of 2003) hereinafter referred to as “the Act”
 - (i) and under the authority of a resolution of the National Assembly, exclude the land described in Schedule 1 hereto, from the Addo Elephant National Park, and
 - (ii) amend the definition of the area of the said park in Schedule 1 to the Act by the deletion of the land defined in Schedule 1.



**MARTHINUS VAN SCHALKWYK, MP
MINISTER OF ENVIRONMENTAL AFFAIRS AND TOURISM**

SCHEDULE

The Remainder of Portion 1 of the farm Henderson 410, Somerset East Registration Division, Eastern Cape Province, in extent 706,5253 hectares, (see L.G. No. 2169/2003) from the Addo Elephant National Park.

No. 232

29 February 2008

**NATIONAL ENVIRONMENTAL MANAGEMENT: PROTECTED AREAS ACT,
2003 (ACT NO. 57 OF 2003)**

**INTENTION TO DECLARE CERTAIN LAND SITUATED IN THE BREDASDORP
REGISTRATION DIVISION, WESTERN CAPE AREA AS PART OF THE AGULHAS NATIONAL
PARK**

I, Marthinus Christoffel Johannes van Schalkwyk, Minister of Environmental Affairs and Tourism, by virtue of the powers vested in me under Section 20(1)(a)(ii), hereby give notice in terms of section 33 (1)(a) of my intention to declare the properties listed in the Schedule as part of the Agulhas National Park.

I hereby invite members of the public to submit written representations on or objections to the proposed notice within 60 days from the date of this notice, by submitting it to the following postal, fax or e-mail address:

The Director-General
Department of Environmental Affairs and Tourism
Private Bag X447
PRETORIA
0001

Attention: Ms S Mancotywa
Fax No: (012) 320 1243/322 7114
E-mail: smampe@deat.gov.za

Comments received after the closing date will be disregarded

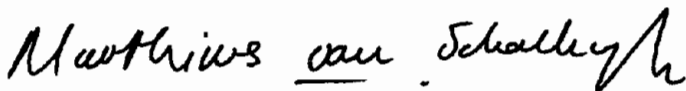

**MARTHINUS VAN SCHALKWYK
MINISTER OF ENVIRONMENTAL AFFAIRS AND TOURISM**

SCHEDULE

The following land is considered for inclusion in the Agulhas National Park.

1. Remainder of the Farm Rhenoster Kop No. 285, Bredasdorp Registration Division, Western Cape Province, measuring 461, 7178 hectares in extent and held by Title Deed No. T101072/2002;
2. Portion 1 of the Farm Rhenoster Kop No. 285, Bredasdorp Registration Division, Western Cape Province, measuring 303, 8139 hectares in extent and held by Title Deed No. T101072/2002;
3. Remainder of the Farm No. 287, Bredasdorp Registration Division, Western Cape Province, measuring 203, 5144 hectares in extent and held by Title Deed No. T101074/2002;
4. Farm No. 287, Bredasdorp Registration Division, Western Cape Province, measuring 1665, 5171 hectares in extent and held by Title Deed No. T101074/2002.

No. 233

29 February 2008

**NATIONAL ENVIRONMENTAL MANAGEMENT: PROTECTED AREAS ACT,
2003 (ACT NO. 57 OF 2003)**

**INTENTION TO DECLARE CERTAIN LAND SITUATED IN THE KQ REGISTRATION
DIVISION, LIMPOPO PROVINCE AS PART OF THE MARAKELE NATIONAL PARK**

I, Marthinus Christoffel Johannes van Schalkwyk, Minister of Environmental Affairs and Tourism, by virtue of the powers vested in me under section 20(1)(a)(ii) hereby give notice in terms of section 33(1)(a) of my intention to declare the properties listed in the Schedule as part of the Marakele National Park.

I hereby invite members of the public to submit written representations on or objections to the proposed notice within 60 days from the date of this notice, by submitting it to the following postal, fax or e-mail address:

The Director-General
Department of Environmental Affairs and Tourism
Private Bag X447
PRETORIA
0001

Attention: Ms S Mancotywa
Fax No: (012) 320 1243/322 7114
E-mail: smampe@deat.gov.za

Comments received after the closing date will be disregarded



MARTHINUS VAN SCHALKWYK

MINISTER OF ENVIRONMENTAL AFFAIRS AND TOURISM

SCHEDULE

The following land is considered for inclusion in the Marakele National Park

1. Portion 3 of the farm Blespaardspruit No. 275, KQ Registration Division, Limpopo Province, measuring 291, 8616 hectares in extent and held by Title Deed No. T94985/2006;
2. Portion 3 of the farm Kareehoek No. 274, KQ Registration Division, Limpopo Province, measuring 297, 5279 hectares in extent and held by Title Deed No. T94986/2006;
3. The remaining extent of the farm Kareehoek No. 274, KQ Registration Division, Limpopo Province, measuring 297, 5279 hectares in extent and held by Title Deed No. T141653/2006;
4. Portion 27 of the farm Hartbeestfontein No. 281, Limpopo Province, measuring 8, 4975 hectares in extent and held by Title Deed No. T57698/2006;
5. Portion 28 of the farm Hartbeestfontein No. 281, KQ Registration Division, Limpopo Province, measuring 8, 4975 hectares in extent and held by Title Deed No. T57698/2006;
6. Portion 29 of the farm Hartbeestfontein No. 281, KQ Registration Division, Limpopo Province, measuring 43, 5636 hectares in extent and held by Title Deed No. T57699/2006;
7. Portion 3 of the farm Hartbeestfontein No. 281, KQ Registration Division, Limpopo Province, measuring 49, 5928 hectares in extent and held by Title Deed No. T57699/2006;
8. Portion 6 of the farm Hartbeestfontein No. 281, KQ Registration Division, Limpopo Province, measuring 81, 7899 hectares in extent and held by Title Deed No. T121763/2001;
9. Portion 15 of the Farm Hartbestfontein No. 281, KQ Registration Division, Limpopo Province, measuring 108, 1972 hectares in extent and held by Title Deed No. T84228/2001;
10. Portion 18 of the farm Hartbeestfontein No. 281, KQ Registration Division, Limpopo Province, measuring 8565, 0000 Square Meters in extent and held by Title Deed No. T84228/2001;
11. Portion 20 of the farm Hartbeestfontein No. 281, KQ Registration Division, Limpopo Province, measuring 604, 7828 hectares in extent and held by Title Deed No. T3606/2003;

12. Portion 10 of the farm Groothoek No. 278, KQ Registration Division, Limpopo Province, measuring 45, 8005 hectares in extent and held by Title Deed No. T57699/2000;
13. Portion 7 of the farm Buffelspoort No. 280, KQ Registration Division, Limpopo Province, measuring 942, 7279 hectares in extent and held by Title Deed No. T78654/2006;
14. Portion 1 of the Farm Buffelspoort No. 280, KQ Registration Division, Limpopo Province, measuring 12, 5768 hectares in extent and held by Title Deed No. T78649/2006.

No. 234

29 February 2008

**NATIONAL ENVIRONMENTAL MANAGEMENT: PROTECTED AREAS ACT, 2003
(ACT NO. 57 OF 2003)**

**INTENTION TO DECLARE CERTAIN LAND SITUATED IN THE MS REGISTRATION DIVISION,
LIMPOPO PROVINCE AREA AS PART OF THE MAPUNGBWE NATIONAL PARK.**

I, Marthinus Christoffel Johannes van Schalkwyk, Minister of Environmental Affairs and Tourism, hereby declare by virtue of the powers vested in me under Section 20(1)(a)(ii) hereby give notice in terms of section 33(1)(a) of my intention to declare the properties listed in the schedule as part of the Mapungubwe National Park.

I hereby invite members of the public to submit written representations on or objections to the proposed notice within 60 days from the date of this notice, by submitting it to the following postal, fax or e-mail address:

The Director-General
Department of Environmental Affairs and Tourism
Private Bag X447
PRETORIA
0001

ATTENTION: Ms S Mancotywa
Fax No: (012) 320 1243/322 7114
E-mail: smampe@deat.gov.za

Comments received after the closing date will be disregarded.

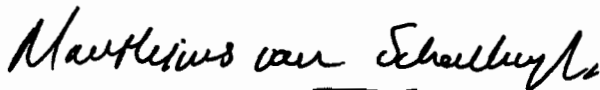

MARTHINUS VAN SCHALKWYK

MINISTER OF ENVIRONMENTAL AFFAIRS AND TOURISM

SCHEDULE

The following land is considered for inclusion in the Mapungubwe National Park.

1. Portion 1 of the Farm Janberry No. 44, MS Registration Division, Limpopo Province, measuring 755, 5492 hectares in extent and held by Title Deed No. T3014/2005;
2. Remainder of the farm Samaria 28, MS Registration Division, Limpopo Province, measuring 431, 9858 hectares in extent and held by Title Deed No. T141762/2004;
3. Portion 3 of the farm Samaria 28, MS Registration Division, Limpopo Province, measuring 431, 9858 hectares in extent and held by Title Deed No. T141762/2004;
4. Portion 3 of the Farm Welton 16, MS Registration Division, Limpopo Province, measuring 708, 0486 hectares in extent and held by Title Deed No. T103662/1997 and T46309/1998.

No. 235

29 February 2008

**NATIONAL ENVIRONMENTAL MANAGEMENT: PROTECTED AREAS ACT, 2003 (ACT NO. 57
OF 2003)**

**INTENTION TO DECLARE CERTAIN LAND SITUATED IN THE NAMAQUALAND
REGISTRATION DIVISION, NORTHERN CAPE PROVINCE AS PART OF THE NAMAQUA
NATIONAL PARK**

I, Marthinus Christoffel Johannes van Schalkwyk, Minister of Environmental Affairs and Tourism, by virtue of the powers vested in me under section 20(1)(a)(ii), hereby give notice in terms of section 33(1)(a) of the of my intention to declare the properties listed in the Schedule as part of the Namaqua National Park.

I hereby invite members of the public to submit written representations on or objections to the proposed notice within 60 days from the date of this notice, by submitting it to the following address:

The Director-General
Department of Environmental Affairs and Tourism
Private Bag X447
PRETORIA
0001

Attention: Ms S Mancotywa
Fax: (012) 320 1243/ 322 7114
E-mail: smampe@deat.gov.za

Comments received after the closing date will be disregarded

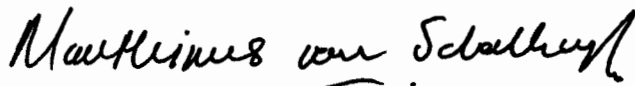

**MARTHINUS VAN SCHALKWYK
MINISTER OF ENVIRONMENTAL AFFAIRS AND TOURISM**

SCHEDULE

The following land is considered for inclusion in the Namaqua National Park:

1. The remaining extent of the farm Rodeklipheuvel No. 470, Namaqualand Registration Division, Northern Cape Province, measuring 1 419,4421 hectares in extent and held by Title Deed No. T77675/2005;
2. Portion 4 (a portion of portion 3) of the farm Kwoap No. 494, Namaqualand Registration Division, Northern Cape Province, measuring 75,1079 hectares in extent and held by Title Deed No. T95383/2005;
3. Farm Vorentoe No 493, Namaqualand Registration Division, Northern Province, measuring 2084, 2203 hectares in extent and held by Title Deed No. T95383/2005;
4. Portion 2 (Taaibosch Duin) of the farm No.477, Namaqualand Registration Division, Northern Cape Province, measuring 907,2230 hectares in extent and held by Title Deed No. T102624/2005;
5. Portion 1 of the farm Graskom No. 483, Namaqualand Registration Division, Northern Cape Province, measuring 855,6560, hectares in extent and held by Title Deed No. T102624/2005;
6. The remainder of the farm Graskom No.483, Namaqualand Registration Division, Northern Cape Province, measuring 1919,5172 hectares in extent and held by Title Deed No. T81192/2005;
7. Portion 1 (Duinen) of the farm Roodelaagte No. 476, Namaqualand Registration Division, Northern Cape Province, measuring 782,4177 hectares in extent and held by Title Deed No. T64984/2006;
8. Portion 2 (Voor Os) of the Farm Roodelaagte No. 476 , Namaqualand Registration Division, Northern Cape Province, measuring 876,1023 hectares in extent and held by Title Deed No. T64984/2006;
9. The remainder of Portion 4 (Hardeleegte) of the farm Roodelaagte No. 476 Namaqualand Registration Division, Northern Cape Province, measuring 1054,9534 in extent and held by Title Deed No. T64984/2006;
10. Farm No. 623, Namaqualand Registration Division, Northern Cape Province, measuring 2691,4319 hectares in extent and held by Title Deed No. T64984/2006;

No. 236

29 February 2008

**NATIONAL ENVIRONMENTAL MANAGEMENT: PROTECTED AREAS ACT, 2003 (ACT NO. 57
OF 2003)**

**INTENTION TO DECLARE CERTAIN LAND SITUATED IN THE KENHARDT REGISTRATION
DIVISION, NORTHERN CAPE AS PART OF THE AUGRABIES FALLS NATIONAL PARK**

I, Marthinus Christoffel Johannes van Schalkwyk, Minister of Environmental Affairs and Tourism, by virtue of the powers vested in me under section 20(1)(a)(ii) hereby give notice in terms of section 33(1)(a) of my intention to declare the properties listed in the Schedule as part of the Augrabies Falls National Park.

I hereby invite members of the public to submit written representations on or objections to the proposed notice within 60 days from the date of this notice, by submitting it to the following postal, fax or e-mail address:

The Director-General
Department of Environmental Affairs and Tourism
Private Bag X447
PRETORIA
0001

Attention: Ms S Mancotywa
Fax No.: (012) 320 1243/ 322 7114
E-mail: smampe@deat.gov.za

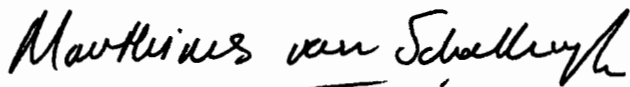

**MARTHINUS VAN SCHALKWYK
MINISTER OF ENVIRONMENTAL AFFAIRS AND TOURISM**

SCHEDULE

The following land is considered for inclusion in the Augrabies Falls National Park:

1. Portion 56 (a portion of portion 48) in extent of the farm Zeekoe-Steek No.9, Kenhardt Registration Division, Northern Cape Province, measuring 1, 1991 hectares in extent and held by Title Deed No. T32392/2006;
2. Portion 13 of the farm Rooipad No.15, Kenhardt Registration Division, Northern Cape Province, measuring 1, 8979 hectares in extent and held by Title Deed No. T79267/2005;
3. Portion 14 of the farm Rooipad No.15, Kenhardt Registration Division, Northern Province, measuring 25, 5022 hectares in extent and held by Title Deed No. T79267/2005;
4. Portion 5 of the farm Omdraai No.492, Kenhardt Registration Division, Northern Cape Province, measuring 3 001, 6988 hectares in extent and held by Title Deed No. T3027/1995;
5. Portion 2 of the farm Nelshoop No. 12, Kenhardt Registration Division, Northern Cape Province, measuring 1 775, 0263, hectares in extent and held by Title Deed No. T89880/2002.

No. 237

29 February 2008

**NATIONAL ENVIRONMENTAL MANAGEMENT: PROTECTED AREAS ACT, 2003 (ACT NO. 57
OF 2003)**

**INTENTION TO DECLARE CERTAIN LAND SITUATED IN THE CALVINIA, CERES AND
SUTHERLAND DIVISION, NORTHERN CAPE AREA AS PART OF THE TANKWA-KAROO
NATIONAL PARK**

I, Marthinus Christoffel Johannes van Schalkwyk, Minister of Environmental Affairs and Tourism, by virtue of the powers vested in me under section 20(1)(a)(ii) hereby give notice in terms of section 33(1)(a) of my intention to declare the properties listed in the Schedule as part of the Tankwa-Karoo National Park.

I hereby invite members of the public to submit written representations on or objections to the proposed notice within 60 days from the date of this notice, by submitting it to the following postal, fax or e-mail address:

The Director-General
Department of Environmental Affairs and Tourism
Private Bag X447
PRETORIA
0001

Attention: Ms S Mancotywa
Fax No.: (012) 320 1243/322 7114
E-mail: smampe@deat.gov.za

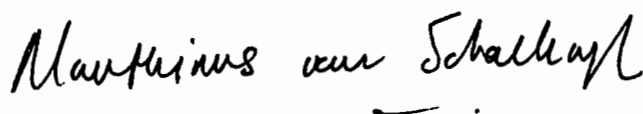

MARTHINUS VAN SCHALKWYK
MINISTER OF ENVIRONMENTAL AFFAIRS AND TOURISM
2008-01-14

SCHEDULE

The following land is considered for inclusion in the Tankwa-Karoo National Park:

1. The farm Gannanga No. 1028, Calvinia Registration Division, Northern Cape Province, measuring 1 400,4812 hectares in extent and held by Title Deed No. T974561/2005;
2. Remaining extent of farm Kleinfontein No. 1027, Calvinia Registration Division, Northern Cape Province, measuring 3527,0681 hectares in extent and held by Title Deed No. T73944/2005;
3. Portion 1 of the farm Brandewynsbank No. 1030, Calvinia Registration Division, Northern Cape Province, measuring 69,8502 hectares in extent and held by Title Deed No. 73944/2005;
4. The farm Roode Werf No. 1091, Calvinia Registration Division, Northern Cape Province, measuring 1490,7013 hectares in extent and held by Title Deed No. T100067/2005;
5. Remainder of the farm Boezak No. 1090 No. 281, Calvinia Registration Division, Northern Cape Province, measuring 3288,9187 hectares in extent and held by Title Deed No. T31010/2005;
6. Remaining extent of the farm Lange Kloof No. 60, Sutherland Registration Division, Northern Cape Province, measuring 1563,0271 hectares in extent and held by Title Deed No. T9280/2006;
7. The farm Annex Klein Fontein No. 61, Sutherland Registration Division, Northern Cape Province, measuring 1238,5869 hectares in extent and held by Title Deed No. T3944/2005;

8. Farm Rooi Werf No.2, Ceres Registration Division, Western Cape Province, measuring 2522,8650 hectares in extent and held by Title Deed No. T92805/2006;

9. Farm De Zyfer No.1, Ceres Registration Division, Western Cape Province, measuring 3259,9608 hectares in extent and held by Title Deed No. 92805/2006.

**DEPARTMENT OF HOME AFFAIRS
DEPARTEMENT VAN BINNELANDSE SAKE**

No. 226

29 February 2008

BIRTHS AND DEATHS REGISTRATION ACT, 1992, (ACT NO. 51 OF 1992) NOTICE OF RECTIFICATION

**ASSUMPTION OF ANOTHER FORENAME IN TERMS OF SECTION 24 OF THE BIRTHS AND DEATHS
REGISTRATION ACT, 1992 (ACT NO. 51 OF 1992)**

Notice is hereby given of Government Gazette Notice No. **76** which, was published in Government Gazette No. **30697** dated **01 February 2008**, is hereby rectified to read as follows:

1. Husan Mohamed Saleh – 570317 5824 089 – 29 Road, 705 Monford, Chatworth, 4092 – *Hoosain Sallie*

No. 227

29 February 2008

BIRTHS AND DEATHS REGISTRATION ACT, 1992, (ACT NO. 51 OF 1992) NOTICE OF RECTIFICATION**ASSUMPTION OF ANOTHER SURNAME IN TERMS OF SECTION 26 OF THE BIRTHS AND DEATHS REGISTRATION ACT, 1992 (ACT NO. 51 OF 1992)**

Notice is hereby given of Government Gazette Notice No. **79** which, was published in Government Gazette No. **30697** dated **04 February 2008**, is hereby rectified to read as follows:

1. Npjao Phillip Tsepetsi – 480820 5202 080 – your wife – Dudu Aletta Tsepedi – 530130 0360 085 – and one minor child - Matthews Mosothwane Tsepetsi – 920625 5450 086 – 3047 Boitumelo, Sebokeng, 1983 – *Makube*
2. Vusi Isaac Ndlovu – 690628 5309 086 – Magoda Area, Richmond, 3780 – *Mazibuko*
3. Nonhlanhla Fortunate Ndlovu – 780926 0355 085 – P O Box 22884, Maranhill, 3610 – *Ngcobo*
4. Samson Suhla Mtshweni – 681203 5683 087 – P O Box 1294, Kwa Mhlanga, 1022 – *Skosana*
5. Kenneth Tisetso Matloung – 880322 6203 080 – 4372 More Street, Duduza, 1496 – *Mofokeng*
6. Mxolisi Tila – 460507 5168 080 – 45 Morning Star Drive, Khwezi, 7784 – *Ntila*
7. Thembinkosi Richman Ndesi – 660709 5795 080 – his wife – Nozuko Gladys Ndesi – 701120 1137 080 – and two minor children – Asive Ndesi – 950928 0512 089 – Mihle Ndesi – 990708 0151 084 – 16115 Seiso Mokhe Street, Phase 2, Bloemfontein, 9323 – *Fono*

Notice is hereby given of Government Gazette Notice No. **791** which, was published in Government Gazette No. **30220** dated **31 August 2007**, is hereby rectified to read as follows:

8. Johannes Christoffel Müller – 660303 5107 080 – 94 Gawood Street, Cradock, 5880 – *Goldie*
9. Lucky Maswanganyi – 871104 5658 089 – Stand No 309, Nbaula, Phalaborwa, 1390 – *Ndebele*

Notice is hereby given of Government Gazette Notice No. **73** which, was published in Government Gazette No. **30697** dated **01 February 2008**, is hereby rectified to read as follows:

10. Husan Mohamed Saleh – 570317 5824 089 – 29 Road, 705 Monford, Chatworth, 4092 – *Sallie*

Notice is hereby given of Government Gazette Notice No. **80** which, was published in Government Gazette No. **30697** dated **01 February 2008**, is hereby rectified to read as follows:

11. Aaron Boswell Manonka – 650705 5277 089 – P O Box 69, Komatipoort, 1340 – *Mantshintshi*

Notice is hereby given of Government Gazette Notice No. **78** which, was published in Government Gazette No. **30697** dated **01 February 2008**, is hereby rectified to read as follows:

12. Petros Vusumuzi Xaba – 630415 5610 082 – and two minor children – Xolisile Josephine Xaba – 961024 338 084 – Mthokozisi Rudolph Xaba – 910627 5370 084 – 376 Dlomo Street, Phola, Ogies, 2230 – *Mahlangu*
13. Freddie Mazini – 690503 5609 084 – 9886 Mophizina Street, Orlando West, 1804 – *Mazibuko*
14. Tebogo Princess Ndlovu – 860912 1207 088 – 3684 Zone 10, Meadowlands, 1852 – *Masike*
15. Promise Thobile Mlaba – 821008 0224 089 – and one minor child – Thando Snikiwe Mlaba – 030331 1288 086 – Kwa-Dabeka Clinic Clernvile, Durban, 3602 – *Ndarana*

16. Mogonono Jaftas Tshiloane – 460403 5272 082 – PO Box 7091, Dithakong, 8604 – *Tshirang*
17. Dieketseng Motshoeneng – 840430 1015 083 – 186 Mokoena Section, Katlehong, 1431 – *Tsotetsi*
18. Thulani Luckyman Ndaba – 700830 5346 088 – and your wife – Nozipho Ronnel Langa – 720205 0417 083 – P O Box 1543, Ladysmith, 3370 – *Langa*
19. Napo Petrus Shelabaka – 640301 5602 089 – and your wife – Dipuo Elizabeth Shelabaka – 680928 0672 088 – 5150 Bloemside, Bloemfontein, 9301 – *Makara*
20. Mzinto Gilbert – 320708 5230 082 – and your wife – Tshonaphi Gilbert – 300609 0120 084 – P O Box 1274, Flagstaff, 4810 – *Nophakela*
21. Zanaye Nobale – 360707 5548 080 – and your wife – Nogcinile Nobala – 521215 0925 085 – Private Bag X3113, Butterworth, 4960 – *Makaluza*
22. Matewu Mathews Madi – 301107 55190 086 – F112 Modderspruit, Brits, 0250 – *Mazibuko*
23. Wynand Kotze – 781205 5076 088 – and your wife – Debora Kotze – 820108 0554 187 – 23 Ingred Crescent, Strand, 7140 – *Rühle*
24. Mofirst Nobuyile Mtozana – 400511 0855 081 – and one minor child – Phaphamani Mtozana – 950802 6089 089 – 3546 Gquetha Street, Ntokozweni, Old Cross Road, Nyanga East, 7750 – *Nkwamza*

Notice is hereby given of Government Gazette Notice No. **122** which, was published in Government Gazette No. **30721** dated **08 February 2008**, is hereby rectified to read as follows:

25. Modisaotsile Wilson Senosi – 650919 5771 088 – P O Box 4998, Gopane, 2882 – *Maletswa*

Notice is hereby given of Government Gazette Notice No. **165** which, was published in Government Gazette No. **29651** dated **02 March 2007**, is hereby rectified to read as follows:

26. Mketwa Dlamini – 690611 5482 087 – and three minor children – Sabelo Percival Dlamini – 960307 6077 082 – Senzo Blessing Dlamini – 931028 5471 089 – Mzami Aubrey Dlamini – 000929 6029 086 – P O Box 598, Estcourt, 3310 – *Khumalo*

Notice is hereby given of Government Gazette Notice No. **329** which, was published in Government Gazette No. **29791** dated **02 March 2007**, is hereby rectified to read as follows:

27. Kesentseng Faiya Nkoatlé – 870503 0379 081 – and one minor child – Sibuyeng Given Nkoatlé – 050929 5739 080 – P O Box 29, Stenbokpan, Lephalele, 0533 – *Nkwati*

No. 228

29 February 2008

**ALTERATION OF SURNAMEN IN TERMS OF SECTION 26 OF THE BIRTHS AND DEATHS REGISTRATION ACT, 1992
(ACT NO. 51 OF 1992)**

The Director-General has authorized the following persons to assume the surname printed in *italics*:

1. Thabang Benedict Maboe – 760905 6172 084 – 6923 Zonkiisizwe, Zone 2, Katlehong, 1431 – *Tshabalala*
2. Oscar Moyahabo Ramaboea – 690724 5667 084 – 23 Bethlehem Drive, Rustenburg, 0299 – *Makgaka*
3. Mahelekietseng Alfred Kwinda – 710505 6127 087 – 157 Motsoaledi, Diepkloof, 1864 – *Ndou*
4. Elias Madwaleni Gumede – 730320 5401 087 – 1347 First Avenue, Mhluzi, 1053 – *Mavuso*
5. Lucky Zakhele Ngubeni – 770521 5655 082 – P O Box 800, Kwazamokuhle, 1098 – *Ngwenya*
6. Lawrence Nkosi – 700404 6745 084 – 299 Makunyane Street, Mhluzi, 1053 – *Molambo*
7. Mpho Yvette Ntengo – 770417 0431 084 – 22 Corobrick Estate, Stilfontein, 2551 – *Serobatse*
8. Simphiwe Yvonne Zondi – 851207 0718 081 – P O Box 1059, Greytown, 3250 – *Msimango*
9. Joice Thembi Ngubane – 761109 0674 083 – Private Bag x 378, Kwangwanase, 3973 – *Masinga*
10. Katlego Julies Mokedi – 630501 6003 086 – P O Box 507, Mothibistad, 8474 – *Pitiele*
11. Mailola Kole Selala – 770528 5750 086 – P O Box 221, Sekwati, 1063 – *Mailola*
12. Makhosazana Francina Mthimunya – 790824 0693 082 – 1259 Moetawalo Street, Mhluzi, 1063 – *Nkosi*
13. Wajid Khan Muhammed – 720620 6501 187 – 1329 Belebela, Belabela, 0480 – *Khan*
14. Silindelo Forytventure Msani – 760829 5411 089 – P O Box 3621, Pietermaritzburg, 3200 – *Mbhele*
15. Matsobane Robert Kekana – 730303 5864 082 – P O Box 122, Mokopane, 0600 – *Leso*
16. Gcinikhaya Robert Mcaba – 740820 6093 088 – 68 Hattinga Street, Ecansfontein, 1401 – *Mngambi*
17. Selemtasela Virgilia Malema – 860417 0160 080 – 17 Hoogenhout Street, Lindhaven, 1724 – *Lebeko*
18. Nkosinathi Emmanuel Gwambe – 840208 5344 083 – Private Bag x 5511, Scottburgh, 4180 – *Sibaya*
19. Riccardo Jaremane Mokolo – 880428 5613 086 – P O Box 1824, Groblersdal, 0470 – *Mashigo*
20. Veli Council Hlongo – 800305 5245 084 – P O Box 2112, White River, 1240 – *Mhlongo*
21. Maria Ntombini Mhlanga – 600127 0623 087 – P O Box 336, Mtubatuba, 3935 – *Mthembu*
22. Sontaga Victor Thokolo – 650906 5374 088 – 9853 Winnie Mandela Section, Tembisa, 1632 – *Raseruthe*
23. Petrus Zabi Shabalala – 771125 5577 087 – 2338 JB Max Street, MasechabaView, 1496 – *Dlamini*
24. Matlho Jan Monare – 730719 5395 084 – 401 Zwelethu, Rustenburg – *Tokwana*
25. Xolani Jacob Hlanguza – 700612 5919 084 – C 847 Amatikulu Road, P O Kwa Mashu, 4359 – *Zulu*
26. Thamsanqa Africa Cibane – 700312 5776 085 – HX1 /282, Umalazi Township, 4031 – *Banda*
27. Shiane Clive Lebelo – 790228 6079 082 – 800 Block x, Mabopane, 0190 – *Mphane*

28. Malibongwe Jijimba – 740412 5768 082 – P O Box 10105, Meerensee, 3901 – *Mnyingwa*
29. Zandile Barbara Mathenjwa – 711106 0910 088 – P O Box 2334, Medunsa, 0204 – *Dlamini*
30. Brian Ayanda Palmer – 770524 5289 084 – 2 Waterloo Green, Wynberg, 7800 – *Khonto*
31. Makgalethi Jane Ngwepe – 770212 0531 086 – P O Box 2301, Mahwelereng, 0626 – *Mofomme*
32. Tando Patrick Liweni – 720416 5622 086 – 10 Javu Street, Zwide – *Mnyazi*
33. Angelin Khabu – 641214 0828 089 – 4 Swart Hout Street, Sonne Veld Minn, Ebron, 1549 – *Kgabo*
34. Susan Malema – 890519 0480 089 – 1752 Mapetla Extension, P O Chiawelo, 1818 – *Phofa*
35. Rooi Rakgalakane – 670715 5542 081 – P O Box 173, Mhluzi, 1053 – *Chego*
36. Godfrey Motlhake – 811115 5316 083 – P O Box 24, Saulspoort, 0318 – *Boqo*
37. Joseph Okafor – 710830 5724 183 – 28 Puerto Rico Diepkloof Street, Wigeheuwel – *Onwuzukile*
38. Mpho Gladwell Serema – 780419 5241 086 – 412 Mphahlele Street, Moroka North, 1818 – *Ramothobi*
39. Velaphi Mzinyane – 741016 5610 084 – 310 Dlamini 2, P O Chiawelo, 1818 – *Zwane*
40. Lucky Letsoara – 780228 5660 082 – 1299 Mkhombe Street, Pimville, 1808 – *Qakwane*
41. Bhekithemba Mahlangu – 850704 6043 085 – Dindela, Mpundulle, 1057 – *Sibiya*
42. Zanele Patience Mchunu – 880302 0942 081 – Sorpulane School, Umbumbulu, 4105 – *Makhanya*
43. Evelyn Chaka – 751005 0252 080 – 5218 Mafata, Phahameng Location, 9323 – *Rantsatsi*
44. Tjotji Jarman Tsotetsi – 740628 5349 082 – 15873 Extension 9, Orange Farm, 1805 – *Mofokeng*
45. Nhlanhla Cyril Sithole – 820627 5335 086 – P O Box 29173, Imbali, 3219 – *Shezi*
46. Yoliswa Kepe – 820716 0561 083 – 506 Charlston House, Commissioner and Delters, Johannesburg – *Kepe*
47. Sibongiseni Blessing Ndaba – 870524 5396 086 – , Pinetown, 1067 – *Ngobese*
48. Humbulani Thomas Phalandwa – 651111 5097 081 – P O Box 3134, Sibasa, 0970 – *Sibara*
49. Zephania Mavuso – 601025 5839 089 – P O Box 48, Mbazwana, 3974 – *Zikhali*
50. Wilfred Sifiso Dube – 821016 5825 081 – 17 Cape Clay Crescent, Phoenix, 3120 – *Shezi*
51. Mbali Allowishia Nkosi – 880114 0724 082 – 1721 B Tshalimpi Street, Zola North, 1868 – *Tshabalala*
52. Mondli Alson Sithole – 800910 5335 080 – Private Bag x 973, Pietermaritzburg, 3201 – *Mthembu*
53. Nomnotho Lydia Mabaso – 880830 0374 087 – Private Bag x 973, Pietermaritzburg, 3201 – *Mpulo*
54. Bukisile Gladys Mkize – 850728 0378 080 – P O Box 300, Highflats, 3306 – *Phungula*
55. Bhekuyise Sibiya – 830202 5500 085 – 19 Bernard Street, Martindale, 2092 – *Mathabela*
56. Thokozani Jacob Mahlangu – 830412 5864 080 – P O Box 2613, Leslie, 2265 – *Skosana*

57. Thulani Edison Siciko – 880526 5422 083 – P O Box 215, Margate, 4275 – *Tshezi*
58. Hendriette Nompumelelo Masina – 880615 0364 083 – 5665 Mtsuki Street, Ackerville, 1039 – *Ngoato*
59. Mudanalo Julia Sadiki – 620516 0369 087 – P O Box 7196, Tzaneen, 0855 – *Sathekge*
60. Eric Jackson Sithole – 811010 5622 087 – P O Box 149, Siyabuswa, 0472 – *Mudaca*
61. Emmanuel Mavimbela – 780924 5476 087 – A1426, Inanda, 4310 – *Mkhwanazi*
62. John Msotho – 550223 5335 080 – P O Box 119, Sehlakwane, 1047 – *Mokwena*
63. Hendry Trust Mathebula – 730429 5336 084 – P O Box 916, Acornhoek, 1360 – *Nxumalo*
64. Patrick Sibongakonke Ndlovu – 610308 5755 086 – P O Box 609, Pinetown, 3610 – *Ndlovu*
65. Kenneth Matshediso – 870207 5538 085 – 1811 Hertzriver Street, Toekomsrus, 1759 – *Magula*
66. Solomon Ace Moima – 781123 5475 087 – 6727 Phetla Street, Section S, Mamelodi West, 0122 – *Lebotse*
67. Sibusiso Mboiyiseni Mzobe – 681008 5705 081 – P O Box 1008, Greytown, 3250 – *Khoza*
68. Alpheus Khathaze Chaba – 831105 5789 088 – 510 Makhulong Section, Tembisa, 1632 – *Sadike*
69. Joseph Siwata Manyapja – 460313 5292 084 – P O Box 3713, Letaba, 0870 – *Shilenge*
70. Mogola Simon Likhuleni – 570912 5756 081 – 440 Mimosa Street, Lynwood – *Malekane*
71. Ephraim Phakiso Thibakgoane – 850407 6124 083 – 1475 Mxi Street, Thabong, 9463 – *Leseme*
72. Ndifelani Theophilus Netshiongolwe – 761016 5664 086 – P O Box 949, Vhufuli, 0971 – *Tshiokovhi*
73. Goodness Fakazile Sindane – 800404 1014 089 – P O Box 4630, Richmond, 3780 – *Sithole*
74. Bulelani Jackson Dyanvane – 800605 5423 080 – 23809 Mhlazana Street, Wallacedene, Kraaifontein, 7570 – *Dyasi*
75. Lesetja Isaac Letswalo – 880423 5871 081 – 967 Namakgale, Namakgale, 1391 – *Seshoka*
76. Hilda Priska Khosa – 880729 0975 085 – P O Box 307, Mamitwa, 0871 – *Thibani*
77. Phillip Lazarus – 060403 5689 085 – Private Bag x 136, Pretoria, 0002 – *Sekete*
78. Ntabodis Albert Mphelo – 770526 5661 089 – 3122 Block B, Mabpoane, 0190 – *Sathekge*
79. Nompumelelo Mkhwanazi – 791130 0397 081 – P O Box 420, Kwadlangezwa, 3886 – *Nkwanyana*
80. Seuntjie Johannes Hlongwane – 550306 5556 084 – 473 Zulu Street, Zithobeni, 1024 – *Hlongwane*
81. Livi Nelson Koti – 560718 5267 082 – 1084 Boqo Street, Kwazakhele, 6205 – *Mabandla*
82. Peter Mandla Stuurman – 810725 5326 089 – 11409 Extension 8, Mhluzi – *Sindane*
83. Thobekile Zondi – 890730 0118 088 – P O Box 688, Nqutu, 3135 – *Mazibuko*
84. Koti Piet Tandari – 290101 6023 084 – P O Box 1058, Tshilwavhusiku, 0938 – *Mutandari*
85. Oupaki Johannes Mosweunyane – 740209 5678 083 – 1212 Langa Street, Vosloorus, 1475 – *Mothibi*
86. Muzikayifani Jetro Zondo – 710103 5992 089 – P O Box 6125, Richards Bay, 3900 – *Mthiyane*

87. Mokete Simon Mokoena – 710102 6695 089 – 240 Ramaphasa Squater Camp, Extension 1, Boksburg – *Rasweu*
88. Samuel Ditshele Rankeng – 730505 6399 087 – P O Box 7717, Rustenburg, 0300 – *Mogakabe*
89. Jabulani Japhta Maduna – 710306 5474 087 – 10744 Ivory Park, Midrand, 1685 – *Mashego*
90. Reuben Mzobanzi Buthelezi – 790321 5784 081 – P O Box 82214, Empangeni, 3880 – *Mbhamali*
91. Dorah Madira Makhoeting – 741213 0610 082 – P O Box 718, Makgofe, 0751 – *Magale*
92. Raymond Mahlangu – 760506 5485 087 – Room 2 Karee Hostel, Marikana, 0284 – *Mulungu*
93. Priscilla Dunisani Mbhense – 880227 0388 086 – 1371 Braamfisherville, Roodepoort, 1724 – *Shivambu*
94. Themba Emmanuel Mswane – 880503 5367 089 – 8046 Zone 6, Diepkloof, 1864 – *Thateng*
95. Nhlanhla Goodwill Mhlanga – 840720 5958 084 – P O Box 1160, Mpulazi, 2335 – *Msibi*
96. Lucky Mfaniseni Mncwango – 810511 5934 084 – P O Box 285, Coronation, 3107 – *Mpanza*
97. Chriselda Van Wyk – 860720 0237 083 – P O Box 426, Amersfoort, 2490 – *Moloi*
98. Nkosinathi Blessing Mtolo – 850414 5950 089 – C951 Umlazi Township, Durban, 4031 – *Hlabangane*
99. James Ngobeni – 690911 5459 089 – 30348 Extension 2, Daveyton, 1520 – *Sithole*
100. Jonase Koliwe – 541011 5732 089 – 20 Railway House, Witbank – *Kholiwe*
101. Mandla John Gulama – 460105 5199 088 – Flat R08, Hope City, 1050 – *Goolam*
102. Matlhomola Vincent Baloyi – 770813 5496 082 – 2315 Refentse, Stinkwater, Hamanskraal, 0400 – *Malapane*
103. Lazola Brother Mvikelwa – 870314 5314 085 – P O Box 1008, King Williams Town, 5600 – *Swapi*
104. Samkelo Quza – 861121 5973 088 – P O Box 2316, George, 6530 – *Manyube*
105. Eugin Lungisani Dlamini – 830908 6133 086 – C 751, Umlazi, 4031 – *Mazibuko*
106. Mandla Robert Skosana – 840407 6015 086 – P O Box 902, Kriel, 2271 – *Mkhabela*
107. Kokami Sarel Cholo – 890924 5487 081 – P O Box 413, Rebone, 0617 – *Motlokoana*
108. Sikhosiphi Velangempi Sokhulu – 610316 5326 089 – P O Box 101, Ozwathini, 3242 – *Khubisa*
109. Esther Thoko Mthembu – 501126 0302 080 – Private Bag x 618, Ubombo, 3970 – *Zwane*
110. Oboditse Rebecca Mokgopisi – 390803 0398 086 – P O Box 1099, Ganyesa, 8613 – *Mokgapole*
111. Dingizwe Elphas Zondi – 640410 5954 083 – Private Bag x 1027, Richmond, 3780 – *Ndlovu*
112. Dumisani Mzangwa – 820211 5782 082 – 2051 B Fundudzi Street, Zone 2, Diepkloof, 1864 – *Mngomezulu*
113. Agnes Nomathemba – 840215 0801 082 – 2051 B Fundudzi Street, Zone 2, Diepkloof, 1864 – *Mngomezulu*
114. Lekgolo Gilbert Moshai – 470603 5334 083 – P O Box 1837, Ga Kgapanne, 0827 – *Shai*
115. Magret Mmakokayi Matsheke – 591210 0398 081 – P O Box 55145, Arcadia, 0007 – *Matseke*

116. Lawdick Mabundza – 780110 5765 089 – P O Box 1404, Lulekani, 1392 – *Mabunda*
117. Thabo Seshoka – 891007 5462 087 – P O Box 16, Letaba, 0870 – *Nakana*
118. Matheuwedi Annah Motsepa – 530120 0757 083 – 1288 Zone 4, Seshego, 0742 – *Motsepe*
119. Duduzile Zulu – 890609 0282 088 – P O Box 2280, Nqutu, 3135 – *Mkhize*
120. Michelle Gumede – 880914 0352 085 – 48 A Reiger Road, Austerville, 4052 – *Esbend*
121. Ella Jamnadas Bhikhabhai – 820301 0205 088 – P O Box 435, Bethal, 2310 – *Bhikha*
122. Nomvula Dorah Gumede – 550519 0727 084 – 10261 Poka Street, Orlando West, 1804 – *Tshabalala*
123. Xolisile Bridget Dlamini – 890310 0733 085 – P O Box 270, Paulpietersburg, 3180 – *Xaba*
124. Ethel Masolo Thekiso – 800810 0352 082 – P O Box 29777, Sunnyside, 0132 – *Mogodi*
125. Mdukisi James Tshikudu – 421017 5124 081 – P O Box 125, Tshimbupfe, 0983 – *Tshikhudo*
126. Sandile Perfect Mbamali – 860917 5852 086 – 4166 Nsibini, Nubian Avenue, Cato Manor, 4091 – *Ngcobo*
127. Zotha Simangele Mthimkhulu – 880714 0397 087 – M408 Ntuthane Road, Kwa Mashu, 4360 – *Phakathi*
128. Horst – Peter Uhlenhaut – 520810 5830 180 – P O Box 36, Brackenfell, 7561 – *Plum*
129. Sipiwo Shinga – 721207 5566 087 – H143 Umlazi Township, P O Umlazi, 4031 – *Manana*
130. Eddie Lizo Somlenze – 840929 6083 087 – Ny 7113, Section 2, Gugulethu, 7750 – *Sakati*
131. Maloti Kleinbooi Skhosana – 221111 5274 087 – Private Bag x 4091, Kwamhlanga, 1022 – *Mabhena*
132. Simon Mpho Mkwanzazi – 620623 5242 085 – 3161 Shabangu Street, Sakhile, 2431 – *Mnguni*
133. Jabulile Maria Phadima – 680814 0276 080 – Stand No 688, Extension 2, Delmas, 2210 – *Maseko*
134. Keitumetse Sandy Sesing – 850909 1673 089 – P O Box 3192, Sesheng, 8447 – *Oats*
135. Nkululeko Bantu Mtshali – 830930 5650 084 – P O Box 1045, Nelspruit, 1200 – *Majola*
136. Thatayaone Jan Sebogo – 880814 6054 083 – P O Box 248, Mothibistad, 8474 – *Van Der Pos*
137. Andile Andrew Madodana Koti – 880126 5701 089 – P O Box 13479, The Tramshed, 0126 – *Phora*
138. Erol Rulani Mashego – 880328 5996 087 – P O Box 38422, Faerie Glen, 0043 – *Maluleke*
139. Frans Thabang Makhubela – 880610 6263 082 – 554 Umgeni Street, Chiawelo, 1818 – *Hlatshwayo*
140. Rirhandzu Ishmael Khumalo – 880404 6124 084 – P O Box 799, Nwamitwa, 0871 – *Mukhari*
141. Luxolo Calvin Mokwena – 861230 5630 08 – 12327 Madingoane Street, Daveyton, 1520 – *Ngubentombi*
142. Samuel Ranthebe Manjuwa – 830829 5348 089 – 15 Sandolin Sullivan Street, Lyttelton, 0157 – *Maifo*
143. Jabulani Msimango – 870315 5886 089 – P O Box 195, Sabie, 1260 – *Shipele*
144. Maureen Nontobeko Thibela – 860213 0320 083 – P O Box 9169, Kabokweni, 1245 – *Mnisi*
145. Siphon Derick Ntuli – 760403 5027 087 – P O Box 110, Kwa Mbonambi, 3915 – *Gumede*

146. Xolani Maxwell Chili – 820801 5611 081 – P O Box 1279, Shongwe Mission, 1331 – *Thabethe*
147. Nomfundo Dinah Malatjie – 890630 0299 088 – P O Box 534, Matsulu, 1203 – *Ndzimandze*
148. Phindile Rias Ncabane – 880919 0801 080 – P O Box 2377, Matsulu, 1203 – *Mashaba*
149. Londiwe Teresa Thwala – 870612 0886 084 – P O Box 1226, Piet Retief, 2380 – *Mabuza*
150. Sibonelo Thulasizwe Mbhamali – 880414 5569 080 – P O Box 304, Mtubatuba, 3935 – *Ntuli*
151. Ntombi Jessie Tlapo – 880610 0294 083 – 431C Crutse Street, White City, 1868 – *Nhlapo*
152. Peter Dabula – 710517 5732 080 – Mampondomiseni A / A, Libode, 5160 – *Mbekeni*
153. Zankolana Nyoluka – 400715 5112 080 – P O Box 39, Lusikisiki, 4820 – *Nyoluka*
154. Malibongwe Daniel Bojana – 740514 5923 086 – 42204 Qhela Street, Makaza, Khayelitsha, 7784 – *Dlikilili*
155. Tebogo Bernette Gaillele – 790623 05398 089 – 20356 Makgasane Street, Rocklands, 9323 – *Mathe*
156. Zipho Gift Makhathini – 890604 5422 086 – 9 Swam Crescent, Eastwood, 3201 – *Mkhize*
157. Mogau Johannes Legau – 880412 5685 088 – P O Box 1136, Mokopane, 0600 – *Kutumela*
158. Lwazi Mfoxo – 830415 5469 081 – 17 Gerald Spilkin Street, Ikwezi Township, 5099 – *Khuzo*
159. John Thabiso Bundule – 810607 5921 087 – 4985 Extension 4, Boitekong – *Makamo*
160. Sonwabo Solomon Tubu – 740408 5499 082 – 1622 Zwelihle, Hermanus, 7200 – *Tile*
161. Harry Sigh Mkhonto – 680925 5640 086 – P O Box 2673, Hazyview – *Mokoena*
162. April Elijah Mothibe – 690322 5464 089 – 483 Moloto Street, Zithobeni, Bronkspuit, 1024 – *Masilela*
163. Manqoba Bhekizenzo Mnguni – 880107 5751 084 – P O Box 386, Empangeni, 3880 – *Mtshali*
164. Tlou Thelma Molele – 850105 1630 084 – P O Box 212, Ga Mahoai, 0798 – *Mahwai*
165. Thathezakhe Sandile Magwaza – 860202 6830 088 – P O Box 604, Empangeni, 3880 – *Mhlongo*
166. Zodwa Mpanza – 860601 1142 086 – P O Box 7198, Empangeni, 3910 – *Mthembu*
167. Thobani Michael Ngcobo – 860210 6212 082 – P O Box 119, Bulwer, 3244 – *Dlamini*
168. Linda Eugene Phakathi – 860106 6450 088 – 685 Tsenelong Section, Itala Street, Tembisa, 1632 – *Mahlangu*
169. Themba Gqumeni – 831214 5977 089 – Stanford Street, Lusikisiki – *Ngcethane*
170. Ronny Mhelembe – 701108 5542 082 – P O Box 1421, Letaba, 0870 – *Machimana*
171. Nkululeko Elijah Mtshali – 810427 5471 086 – E310 Gugu Nqobo Road, Umlazi, 4031 – *Vilakazi*
172. Masixole Kofi – 850823 5467 085 – 45 Machel Street, Motherwell, 6211 – *Tose*
173. Sbusiso Mbatha – 860511 5690 081 – 4051 Ivory Park, Midrand – *Nkosi*
174. Lehlohonolo Lota Alfred Maseko – 880512 5695 084 – 3564 Motsekuwa Street, Phuthaditjaba, 9866 – *Motaung*

175. Promise Nono Mhlongo – 781027 0891 083 – P O Box 534, Eshowe, 3815 – *Qwabe*
176. Andrias Mnyamezeli Nene – 750416 5560 081 – 373 Mpumelelo Area, France – *Maluleka*
177. Mmaniki Phillimon Ntsimane – 870826 5766 089 – Lotwane Section, Tlhabane, 2195 – *Mashishi*
178. Wendy Primrose Ngubane – 841005 0282 089 – P O Box 61, Wasbank, 2920 – *Mazibuko*
179. Prudence Thuleleni Sithole – 831224 0081 084 – P O Box 2, Ximhungwe, 1281 – *Mathumbu*
180. Bheki Wonderboy Zwane – 890127 6107 084 – 77 Bekezela Street, Kingsway, 1501 – *Mbuli*
181. Bongani Eric Mchunu – 781120 5318 085 – B1025 Umlazi, P O Umlazi, 4031 – *Ngcece*
182. Jeremy Rendy Meyer – 890902 5061 080 – 19466 Peter Street, Extension 37, Bethisdorp, 6059 – *Gallant*
183. Johannes Gerhardus Boshoff – 80312 5014 080 – P O Box 26174, Monument Park, 0105 – *Boshoff – Serenata*
184. Able Silwayiphi Xulu – 730526 5642 088 – 3070 Sbetha, Piet Retief, 2380 – *Nkwanyana*
185. Mavu Brian Ventshane – 751025 5911 084 – P O Box 27336, Greenacres, 6000 – *Mutenha*
186. Sabelo Mlombi – 810303 5426 083 – 349 Extension 6, Grahamstown, 6139 – *Gwejela*
187. Mosibudi Pertunia Makgoba – 880627 0947 080 – P O Box 146, Letaba, 0870 – *Mohale*
188. Zolile Hamilton Nondilise – 821002 5853 083 – 139Thiteng Section, Tembisa, 1632 – *Nkosi*
189. Andrew Mpho Fakude – 890227 5617 081 – P O Box 910, Whiteriver, 1240 – *Sebothoma*
190. Tebogo Dlunge – 840411 5688 083 – Ny 128 No 25, Section 3, Gugulethu, 7750 – *Hoye*
191. Thandanani Lawrence Mtetwa – 890727 5448 080 – P O Box 15, Piet Retief, 2382 – *Ndhela*
192. Patson Mduduzi Khumalo – 820123 5891 088 – P O Box 32, Vryheid, 3100 – *Mabuza*
193. Sophie Monama – 860629 0748 082 – P O Box 18119, Rabie Ridge, 1688 – *Maidi*
194. Bongani Goodenough Ngwenya – 800717 5756 086 – P O Box 18816, Sunny Park, 1471 – *Mlangeni*
195. Mofu Edmond Setsoboko – 710927 5982 082 – 8590 Meqhelong, Ficksburg, 9730 – *Setloboko*
196. Shadrack Ndobela – 750105 5589 089 – P O Box 92, Mamitwa, 0871 – *Makhubela*
197. Elias Godfrey Skosana – 830302 5407 081 – 6687 Section 5, Mamelodi West, 0122 – *Mokwana*
198. Linda Mangaliso Mdeleleni – 830702 5282 089 – 4730 Thulani Section, Daveyton, 1520 – *Nongwe*
199. Madumetja Obede Mothombeni – 590101 5744 083 – P O Box 223, Koringpunt, 0632 – *Nkwe*
200. Isaac Stemer Mthimunya – 710915 6144 083 – P O Box 79055, Mamelodi East, 0122 – *Msiza*
201. Mandlondoda Bhelukwenza Dlomo – 640121 5762 083 – Private Bag x 7006, Sundumbili, 4491 – *Dladla*
202. Disang Danley Rapelang – 800628 5277 082 – P O Box 1912, Kuruman, 8460 – *Baepi*
203. Khayelihle Nimrod Mazibuko – 840924 5532 085 – Eskom No 442, Dickshalt, Osizweni, 2952 – *Msimango*
204. Phumla Esmarelda Nzenze – 681011 0968 084 – W44 Site B, Khayelitsha, 7784 – *Qwalana*

205. S'celo Eric Kowa – 830223 6286 086 – P O Box 302, Izingolweni, 4260 – *Khowe*
206. Leya Ncabane – 860929 0738 087 – P O Box 2377, Matsulu, 1203 – *Mashaba*
207. Lindelo Ntandokayise Madida – 870502 0658 082 – P O Box 13223, Elspark, 1418 – *Kunene*
208. Thomas Siphing Khoza – 890202 5608 083 – 4238 Block F 3, Eersterust – *Kone*
209. Makena Petrus Mafumane – 660708 5366 082 – 2256 Motihatswa Street, Zone 2, Pimville, 1809 – *Maraka*
210. Bongani Mdluli – 700830 5381 085 – 1014B Ngcobo Street, Emdeni, 1868 – *Mabizela*
211. Zebulon Solomon Mdawu – 700914 5759 084 – 2039 Section 2, Majaneng – *Mabena*
212. Dumisani Vusumuzi Cebekhulu – 710111 5570 086 – P O Box 29, Mtubatuba, 3935 – *Mdletshe*
213. Makeswele Maria Modiba – 511005 0416 082 – P O Box 653, Tholongwe, 0734 – *Nyalungu*
214. Sepeng John Mamogobo – 701215 5476 086 – your wife – Mahlodi Matty Mamogobo – 750630 0786 083 – your three minor children – Matsatsi Daisy Mamogobo – 960213 0668 084 – Gatane Damary Mamogobo – 030427 0191 089 – Makgalatibe Dominic Mamogobo – 060613 1382 081 – P O Box 437, Marishane, 1064 – *Ntombela*
215. Johannes Monyai – 681110 5483 089 – your wife – Mirriam Monyai – 680909 0363 084 – your two minor children – Keabetsoe Monyai – 010916 6073 089 – Kamohelo Monyai – 950506 5530 080 – 1648 Section C, Palm Springs, 1984 – *Mofokeng*
216. Mathapelo Mokoena – 800806 0743 080 – your minor child – Fikile Promise Mokoena – 991110 0680 080 – 3045 Tshepisonq West, Roodepoort, 1724 – *Mazibuko*
217. Petrus Sonnyboy Nhlapo – 590209 5188 084 – 1472 Section C, Palm Springs, Evaton, 0081 – *Makhudu*
218. Skheto Thomas Chauke – 700623 5463 080 – your four minor children – Vonani Decide Chauke – 950712 5864 087 – Vutomi Trezer Chauke – 970709 0777 088 – Vuyelo Marcus Sithole – 031009 5388 081 – Vuenti Motive Chauke – 060412 0625 081 – Private Bag x 9116, Malamulele, 0980 – *Sithole*
219. Lethabo Donald Kobe – 780510 5388 081 – your minor child – Kutloano Nare Kobe – 050831 5347 080 – P O Box 4803, Witbank, 1035 – *Moleele*
220. Caroline Nombulelo Langa – 830621 0464 084 – 141 Uvenyani Street, Kingsway, 1801 – *Tshezi*
221. Sifiso Welcome Makhanya – 720429 5335 088 – your wife – Nompumelelo Makhanya – 721217 0858 082 – K1686 Phothwe Road, Kwa Mashu, 4360 – *Mngazi*
222. Msafiri Mohamed – 750318 6076 184 – your wife – Lizle Mohamed – 840329 0363 086 – your minor child – Rusheda Lerato Mohamed – 040917 0499 084 – Room 14 Huntsman Lodge, Helderberg, Sojmerset West, 8001 – *Nankaranga*
223. Elphus Dumisani Mahlangu – 700904 5658 089 – your wife – Joyce Lindiwe Mahlangu – 700115 1053 080 – your two minor children – Lindokuhle Nkosazana Mahlangu – 990218 0412 080 – Nompumelelo Mahlangu – 030811 1103 088 P O Box 1420, Siyabuswa, 0472 – *Zulu*
224. Bonile Maxin Mayane – 560816 5425 088 – your wife – Thenjiwa Patience Mayane – 740929 0801 089 – 104 Mondile Street, Kwa Nobuhle, 6242 – *Cakwebe*
225. Bangile Khohliso – 710101 9223 089 – your wife – Nolusindiso Gloria Khohliso – 800304 0406 080 – your two minor children – Lukhanyo Khohliso – 000725 5348 083 – Nasiphi Khohliso – 040901 0239 088 – 1475 Freedom Park, Rustenburg, 0299 – *Marongo*

226. Juliath Kholofelo Makhubedu – 801030 0602 084 – your minor child – Elaine Makhubedu – 040519 0959 081 – P O Box 47, Acornhoek, 1360 – *Mohlala*
227. Thilamile Monica Goge – 540619 0390 082 – Private Bag x 011, Inanda, 4310 – *Zondi*
228. Mmutla John Mailula – 530216 5276 085 – your wife – Mamcy Mmakwena Mailula – 611012 0701 082 – 234 Tshepo Section, Tembisa, 1632 – *Mphela*
229. Lucky Mkhwashu – 700722 5548 088 – your minor child – Jaydee Mkhwashu – 060728 5397 085 – P O Box 1021, Thulamahashe, 1365 – *Nkhwashu*
230. Andile Ephraim Magagula – 750823 5460 081 – your minor child – Zinhle Happygirl Princess Magagula – 990830 1155 086 – P O Box 8592, Sakhile, 2431 – *Zondo*
231. Luyanda Leonard Gege – 690629 5661 088 – P O Box 37, Mt Frere, 5090 – *Myambi*
232. Mbuiselo Levin Dzina – 671114 5283 087 – your wife – Malerato Elizabeth Dzina – 731106 0346 081 – your two minor children – Vincent Vuyo Dzina – 960325 5301 089 – Simphiwe Dzina – 991015 0296 086 – 4643 Rammulotsi, Viljoenskroon, 9520 – *Snail*
233. John Mzuvukile Mnyentsana – 590814 5875 083 – your wife – Koliswa Mavis Mnyentsana – 690522 0808 087 – your minor child – Sinazo Mnyentsana – 901221 0921 082 – Private Bag x 526, Mqanduli, 5080 – *Mgolombane*
234. Sarah Maida Madubana – 720424 1059 089 – your two minor children – Lebogang Wendy Madubana – 940321 0616 089 – Frans Katlego Madubana – 890516 5679 087 – P O Box 150, Thinplaas, 0437 – *Nkoane*
235. Moagiemang Gloria Morretsi – 750629 0485 084 – your two minor children – Bonolo Jessica Morretsi – 950612 0357 089 – Dineo Natasha Morretsi – 000426 0373 081 – 20677 Karabo Street, Phuthanang, 8301 – *Binang*
236. Phatolo Florah Rangoato – 600617 0502 083 – your two minor children – Ramaesela Natacia Rangoato – 930219 1054 080 – Lawrence Mafori Rangoato – 971222 6382 084 – P O Box 4013, Tooseng – *Ntswane*
237. Thabo Lucky Zwane – 701223 5644 083 – your wife – Mathapelo Lucky Zwane – 781101 0773 086 – your two minor children – Karabo Innocentia Zwane – 990617 0426 083 – Kamohelo Tshepiso Zwane – 021003 0957 083 – 2263 Mollo Street, Sakhile, 2431 – *Selepe*
238. Dimakatso Elizabeth Molefane – 790214 0459 082 – your minor children – Zakhele Tumelo Molefane – 041116 5741 082 – Private Bag x 2034, Lerato, 2880 – *Maseng*
239. Simo Zamokwakhe Goodfrey Ntsele – 651231 5587 087 – your two minor children – Bandile Luyanda Ntsele – 960331 5386 088 – Siphuxolo Nosipho Ntsele – 020419 0448 082 – P O Box 2009, Ladysmith, 3370 – *Njikelane*
240. Mpostoli Johannes Kganyago – 620418 5906 080 – your wife – Pauline Emmie Kganyago – 660117 0360 084 – your minor child – Sibongiseni Clementine Kganyago – 980126 0606 084 P O Box 1499, Siyabuswa, 0472 – *Mahlangu*
241. Siphon Nathaniel Masina – 640826 5469 089 – P O Box 99, Tembisa, 1632 – *Moleko*
242. Themba Cyril Khanyile – 631023 5656 086 – your wife – Siphumelele Anthea Khanyile – 781228 0593 089 – your three minor child – Hlengiwe Tracy Khanyile – 990610 0230 084 – Lusanda Langelihle Hope Khanyile – 040116 5139 080 – Kuhlekonke Bradley Khanyile – 010705 6045 084 – P O Box 1519, Kwa Dukuza, 4450 – *Mbambo*
243. Thandekile Elliot Mpanza – 660308 5814 080 – your wife – Nopinki Abegaile Mpanza – 740406 0803 084 – your minor child – Ayabulela Mpanza – 060111 5142 080 – W 387 Site B, Khayelitsha, 7784 – *Nashwa*
244. Mtobi Zondani – 680811 5408 080 – your wife – Nonkosi Patricia Zondani – 710524 0501 080 – your minor child – Avuye Zondani – 040601 0081 080 – 42 Piennar Street, Manor Heights, Despatch, 6200 – *Peppeta*
245. Ntiantla Hamilton Nyembe – 650315 5635 086 – Emelyn Nyembe – 670414 0531 089 – Siphwe Innocent Nyembe – 900126 5282 086 – Sandile Ntliziywane – 960220 5293 081 – 336 Mhlali Street, Senaone, 1818 – *Mnyoni*

246. Lucas Julius Masilela – 710712 5697 082 – two minor children – Doctor Thabang Masilela – 010317 5117 086 – Pamela Masilela – 010317 0115 085 – Kiaat Flat, Troye Street 206, Mucleneuk, 0002 – *Masombuka*
247. Vusumuzi Shabalala – 720328 5634 088 – your minor child – Lwandle Shabalala – 960527 5048 087 – P O Box 1739, Saxonworld, 2132 – *Tshabalala*
248. Bridget Bathini Sikhosana – 840321 0655 088 – your minor child – Nomfundo Sikhosana – 000414 0885 080 – 13646 Extension 15, Bakane, 1550 – *Mphande*
249. Emma Makopi Sekwati – 830328 1147 082 – your minor child – Keletso Sekwati – 030127 6115 088 – P O Box 353, Dennilton, 1030 – *Malekutu*
250. Jabulane Jacob Mahlangu – 541126 5678 080 – your wife – Velephi Sarah Mahlangu – 550701 0736 089 – your minor child – Tebogo Joseph Mahlangu – 940717 5678 083 – 353 Wolwekraal, Siyabuswa – *Nkoana*
251. Nareshwana Patrick Seerane – 561010 5984 083 – P O Box 186, Sabie, 1260 – *Malatji*
252. Mandlenkosi Sydwell Ntuntwana – 610608 5456 084 – your wife – Linda Ntuntwana – 650201 0530 086 – your four minor children – Sinovuyo Ntuntwana – 900709 0478 088 – Nomazulu Ntuntwana – 920513 0457 084 – Dumisani Ntuntwana – 980131 5271 082 – Mihlali Ntuntwana – 030226 0784 087 – 65 Ndebe Street, Nu 7, Motherwell, 6211 – *Manzana*
253. Petros Skhosana – 660702 5427 085 – your minor child – Mzwakhe Thabo Skhosana – 060408 5904 083 – Stand BB 139, Extension 16, Kwa Guqa, 1035 – *Mashegoane*
254. Talifhani Justice Makhado – 701213 5637 088 – your wife – Ambani Rachel Makhado – 761001 0505 088 – your two minor children – Andani Makhado – 980615 5049 084 – Vhusani Makhado – 030618 5817 088 – 6662 U – Nongane Street, Extension 9, Marimba Gardens, 1475 – *Thivhafuni*
255. Themba Morgan Gebedu – 750315 6098 085 – 2393 B, Emdeni Extension – *Geledu*
256. Mtutuzeli Hyacinth Mkencele – 590807 5659 085 – your wife – Veronica Mkencele – 560809 0280 087 – 2706A Zone 2, Pimville, 1809 – *Nhlapo*
257. Vincent Vonny Gombelo – 600416 5204 088 – your wife – Edinah Gombelo – 660416 0896 182 – P O Box 53727, Troyville, 2139 – *Pongolani*
258. Siboniso Zwane – 710207 5558 087 – you wife – Thembi Valentia Zwane – 741209 0644 089 – your three minor children – Andile Peace Lindokuhle Zwane – 940104 0695 083 – Thando Mthokozisi Theophilus Zwane – 951110 5630 088 – Sthandiwe Samkellisiwe Zwane – 010308 0368 089 – P O Box 45, Nulam Camden, 2355 – *Nzimand*

No. 229

29 February 2008

**ALTERATION OF SURNAMES IN TERMS OF SECTION 26 OF THE BIRTHS AND DEATHS REGISTRATION ACT, 1992
(ACT NO. 51 OF 1992)**

The Director-General has authorized the following persons to assume the surname printed in *italics*:

1. Sibongiseni Steven Mthiyane – 830121 5837 083 – P O Box 433, Esikhawini, 3887 – *Sibongiseni Steven*
2. Kwena Wilson Shilabjwe – 750903 6136 086 – PO Box 1833, Koloti, 0709 – *Mateka Wilson*
3. Buti Aaron Selepe – 760626 5588 084 – P O Box 5592, Phuthaditjaba, 9866 – *Jadi Aaron*
4. Monica Modiegi Moisi – 870324 0566 084 – P O Box 59, Silverton, 0127 – *Monica Moliehi*
5. Jordan Modise – 751010 6703 086 – 1842 Tswana Section, Carletonville, 2499 – *Eloff*
6. Phasudi Lancelot Lekala – 841108 5395 086 – P O Box 268, Dichoeung, 0476 – *Phasudi Lancelot*
7. Soka Charles Modise – 530702 5673 082 – P O Box 891, Newtown, 2113 – *Seoka*
8. Stephen George Osler Anderson – 811226 5272 083 – P O Box 15589, Vlaeberg, 8018 – *Stephen George*
9. Segole Francina Makgamatha – 411023 0284 088 – 213 Ramokgopa Street, Saulsville, Pretoria, 0125 – *Serole Francina*
10. Thivhavhuzi Mavhungu – 790804 5761 084 – P O Box 3405, Thohoyandou, Vhembe, 0950 – *Thivhavhudzi Richard*
11. Bonginkosi Hammilton Dhlamini – 700506 5664 080 – PO Box 202, Nkandla, Newcastle, 3855 – *Hamilton Bonginkosi*
12. Mabatho Magdeline Mamabolo – 861120 0515 084 – 1067 Zone 4, Seshego, 0742 – *Mpho Josephine*
13. Sibusiso Sylvester Sibiya – 761012 5399 088 – 20 Sompane Street, Saulsville, 0125 – *Bodibe Sibusiso Sylvester*
14. Frederik Pieter Breedt – 791231 5068 089 – 10 Wellington Mews, Wellington Avenue, 7800 – *Franco Jorgito*
15. Mbulelwa Martin Phoseka – 750111 5378 085 – 1125 Section B, Pumpsprings, 1984 – *Mbulelo Martin*
16. Mutshutshu Edward Lutumba – 720925 5989 089 – P O Box 727, Tshaulu, 0987 – *Doyen Eddie*
17. Thembelihle Dladla – 840224 0432 088 – 284 Ramokonopi West, Katlehong, 1431 – *Lindiwe Pearl*
18. Philippus Johannes Du Plessis – 850521 5001 082 – Posbus 16584, Pretoria Noord, 0116 – *Philip Johan*
19. Zandile Mtshali – 890622 0347 082 – House No. 4, Nerina, Springcol – *Zandile Fortunate*

No. 230

29 February 2008

ALTERATION OF FORENAMES IN TERMS OF SECTION 24 OF THE BIRTHS AND DEATHS REGISTRATION ACT, 1992 (ACT NO. 51 OF 1992)

The Director-General has in respect of the following persons approved the alteration of their forenames printed in *italics*:

1. Hendrik Ceasar - 521101 5103 08 6 - Department of Home Affairs, Private Bag X265, Vredendal, 8161 - *Hendrik Johnny*
2. Linda Mthembu - 760321 0272 08 8 - Department of Home Affairs, Private Bag X2012, Krugersdorp, 1740 - *Linda Nosonto*
3. Portia Tebogo Motjieng - 870707 0862 08 3 - Department of Home Affairs, Private Bag X9428, Polokwane, 0700 - *Sarah Tebogo*
4. Wagner Franklin Pietersen - 670119 5489 08 0 - Department of Home Affairs, Private Bag X5, Mitchells Plain, 7789 - *Waleed Faizel*
5. Sygneria Notemba Lukhozi - 760805 0922 08 0 - Department of Home Affairs, Private Bag X514, Ixopo, 3276 - *Sygneria Nomathemba*
6. Stephen Padi - 671019 5469 08 3 - Department of Home Affairs, Private Bag X41, Roodepoort, 1725 - *Sydney Stephen*
7. Terrans Mhlopheki Vilakazi - 870411 5624 08 1 - Department of Home Affairs, Private Bag X11, Boksburg, 1460 - *Terrance Mhlonipheki*
8. Vuyiswa Eustus Maphanga - 711008 5583 08 6 - Department of Home Affairs, Private Bag X54333, Durban, 4000 - *Vukile Eustice*
9. Samuel Kgaolane Moagi - 780927 5648 08 4 - Department of Home Affairs, Private Bag X605, Pretoria, 0001 - *Mcdonald Samuel Kgaolane*
10. Tindi Dollen Mabunda - 830910 5449 08 3 - Department of Home Affairs, Private Bag X9666, Giyani, 0826 - *Tindi Dester*
11. Jan Christoffel Van Der Merwe - 801022 5303 08 1 - Department of Home Affairs, Private Bag X11, Boksburg, 1460 - *Jaun Christo*
12. Evelyn Swartz - 810412 0426 08 7 - Department of Home Affairs, Private Bag X3028, Paarl, 7020 - *Evelyn Monique*
13. Muzi Dumisa Malinga - 861006 6435 08 0 - Department of Home Affairs, Private Bag X9047, Ermelo, 2350 - *Vusumuzi Dumisa*
14. Sesi Gabisile Dlamini - 791010 2660 08 4 - Department of Home Affairs, Private Bag X9047, Ermelo, 2350 - *SEsi Precious*
15. S'bongiseni S'thokozo Dlundla - 891217 6050 08 4 - Department of Home Affairs, Private Bag X9322, Vryheid, 3100 - *S'bongiseni Dumsani*
16. Mieta Morieta Mackay - 770121 0218 08 3 - Department of Home Affairs, Private Bag X11, Johannesburg, 2000 - *Nieta Morieta*
17. Matu Harriet Maseko - 570127 0254 08 7 - Department of Home Affairs, Private Bag X24, Rosslyn, 0200 - *Evodia Dudu*
18. Cindy Nokuthula Qwabe - 820624 1271 08 4 - Department of Home Affairs, Private Bag X09, Greyville, 4023 - *Sindisiwe Nokuthula*
19. Theodora Mnyazana - 650611 0955 08 5 - Department of Home Affairs, Private Bag X2, Khayelitsha, 7793 - *Nosabelo Theodora*
20. Kgomotso Sesupa Sylvester Modiroa - 840709 5449 08 7 - PO Box 835, , Mafikeng, 2745 - *Kgomoso Sesupa Sylvester*
21. Kgaogelo Tshelane Nelson Nchabeleng - 840115 5440 08 6 - PO Box 113, , Lefalane, 0741 - *Tshelane Elson*
22. Avhahumbuli Magidi - 890512 6148 08 1 - Department of Home Affairs, Private Bag X2249 Sibasa, Venda, 0970 - *Humbulani*
23. Nhema Salina Kgwahla - 830119 0448 08 8 - Department of Home Affairs, Private Bag X1, Bergvlei, 2012 - *Khosa Reneilwe*
24. Carlos Anthony Pereira Da Silva - 780805 5032 08 9 - Department of Home Affairs, Private Bag X1 Bridgton, Oudtshoorn, 5623 - *Carlos Antonio*
25. Flory Makgogo Morobane - 870124 0722 08 7 - Department of Home Affairs, Private Bag X605, Pretoria, 0001 - *Flory*
26. Qaba Solomon Mafa - 840322 5636 08 1 - Department of Home Affairs, Private Bag X605, Pretoria, 0001 - *Qaba Solomon Morena*
27. Katazile Nokuthula Lucian Tafeni - 481221 0214 08 0 - Department of Home Affairs, Private Bag X507, Bizana, 4800 - *Nokuthula Lucian*
28. Casper Sibonsiseni Dlamini - 710517 5777 08 5 - Department of Home Affairs, Private Bag X24, Harding, 4680 - *Casper Sibongiseni*
29. Yaneshree Pillay - 750206 0214 08 5 - Department of Home Affairs, Private Bag X74, Bellville, 7535 - *Yanesh*
30. Mancoko Clifford Tase - 370621 5187 08 8 - Department of Home Affairs, Private Bag X5, Mitchells Plain, 7789 - *Mancoko Chiefford*

31. Welhemina Mokoena - 570617 0559 08 9 - Department of Home Affairs, Private Bag X1012, Cullinan, 1000 - *Wilhemina Mmapelo*
32. André Du Plessis - 800810 5070 08 5 - 365 Jan Fiskaal Street, Amstelhof, Paarl East, 7646 - *Aneez*
33. Beinca Mornicq Lombard - 871102 0048 8 2 - Department of Home Affairs, Private Bag X6030, Port Elizabeth, 6001 - *Bianca Monique*
34. Mantele Christina Rakgasa - 761213 0548 08 9 - Department of Home Affairs, Private Bag X45, Itsooseng, 2744 - *Lerato Mantele*
35. Veronica Letsosa - 620813 0427 08 4 - Department of Home Affairs, Private Bag X1, Ferreirasdorp, 2048 - *Veronica nana*
36. Markia Mpala - 641128 5898 08 9 - Department of Home Affairs, Private Bag X007, Vereeniging, 1930 - *Maleke*
37. Hendrik Smal Von Liebenberg - 730228 5122 08 4 - Department of Home Affairs, Private Bag X9031, Cape Town, 8000 - *Heinrich Schmal*
38. Phineas Nvula Mayeki - 851127 5942 08 2 - Department of Home Affairs, Private Bag X13, Welkom, 9460 - *Phineas Mvula*
39. Winston Samuel Pitcher - 630618 5307 08 4 - Department of Home Affairs, Private Bag X5, Mitchells Plain, 7789 - *Ghaliel Bien Whalied*
40. Deon Botha - 830607 5295 08 2 - Department of Home Affairs, Private Bag X605, Pretoria, 0001 - *Deon Louw*
41. Nontokozi Nompamelelo Mlambo - 861219 0285 08 4 - Department of Home Affairs, Private Bag X11, Boksburg, 1460 - *Nontokozi Nompumelelo*
42. Malemadutse Rain Mathabatha - 890831 5582 08 6 - Department of Home Affairs, Private Bag X71, Lebowakgomo, 0737 - *Malemadutse Rhine*
43. Nomvula Winile Colleen Mkhwanazi - 860707 0436 08 8 - Department of Home Affairs, Private Bag X10661, Kwa Dukuza, 4450 - *Winile Colleen*
44. Ebuang Sankie Puongwe - 890224 0434 08 3 - Department of Home Affairs, Private Bag X20, Vryburg, 2660 - *Refitwe*
45. Ongezwa Athi Madaka - 800813 0533 08 1 - Department of Home Affairs, Private Bag X20531, Bloemfontein, 9300 - *Ongezwa Tanlokazi*
46. Mthokozisi Solomon Mcineka - 860923 5271 08 7 - Department of Home Affairs, Private Bag X9005, Pinetown, 3600 - *Mthokozisi Lucky*
47. Doris Adeleen May Roberts - 350502 0256 08 2 - Department of Home Affairs, Private Bag X3028, Paarl, 7620 - *Dorren Adelaide May*
48. Lloyd Mapinye Mmola - 890208 5019 08 0 - Department of Home Affairs, Private Bag X638, Groblersdal, 0470 - *Lloyd Mapulane*
49. Velwano Mpikasho - 570313 6086 08 3 - Department of Home Affairs, Private Bag X20, Mdantsane, 5219 - *Velwano Velile*
50. Merriam Nonyane - 840417 0746 08 1 - Marite Trust, PO Box 210, Bushbuckridge, 1280 - *Merriam Conelia*
51. Mieta Snyers - 801211 0995 08 8 - Department of Home Affairs, Private Bag X74, Bellville, 7535 - *Marelize*
52. Selena August - 831215 5581 08 6 - Department of Home Affairs, Private Bag X71, Uitenhage, 6230 - *David*
53. Siphesihle Ntselelo Challenge Khumalo - 871104 0509 08 9 - Department of Home Affairs, Private Bag X9005, Pinetown, 3600 - *Siphesihle Ntselelo*
54. Philokuhle Gift Shabane - 840821 5134 08 8 - Department of Home Affairs, Private Bag X9005, Pinetown, 3600 - *Phiwokuhle Gift*
55. Nomhlanhla Sarah Mtsweni - 870418 0347 08 9 - PO Box 137, , Leslie, 2265 - *Nonhlanhla Sarah*
56. Freedom Skhululekile Sizwe Ngema - 870613 5284 08 5 - PO Box 5933, , Melmoth, 3835 - *Freedom Sizwe*
57. Nompumelelo Hadebe - 840430 0589 08 8 - Department of Home Affairs, Private Bag X6664, Newcastle, 2940 - *Nomusa Devine*
58. Thembani Elina Madida - 600109 0273 08 9 - Department of Home Affairs, Private Bag X6664, Newcastle, 2940 - *Thembani Elina*
59. Hendrick Ndlazi - 821214 5881 08 5 - Department of Home Affairs, Private Bag X6664, Newcastle, 2940 - *Phumlani Freddy*
60. Nomasonto Jane Jele - 750810 0385 08 2 - Department of Home Affairs, Private Bag X6664, Newcastle, 2940 - *Jeni Uwusonto*
61. Kennedy Siphwe Ndaba - 860719 5776 08 7 - Department of Home Affairs, Private Bag X6664, Newcastle, 2940 - *Kennedy Siphwe*
62. Stenphot Raesetja Choshi - 871202 5678 08 9 - Department of Home Affairs, Private Bag X9426, Polokwane, 0700 - *Mosima Stanford*

63. Spihwe Sydney Nxumalo - 880824 5651 08 6 - Department of Home Affairs, Private Bag X6664, Newcastle, 2940 - *Siphile Sydney*
64. Jabulile Xaba Ntetha - 870626 5434 08 8 - Department of Home Affairs, Private Bag X6664, Newcastle, 2940 - *Sandile*
65. Ntombisaka Ncayiya - 781123 0683 08 1 - Department of Home Affairs, Private Bag X54333, Durban, 4000 - *Ntombisaka Zandile*
66. Zukiswa Gqozo - 841225 1354 08 9 - K18 Xengxe Street, Site B, Khayelitsha, 7784 - *Zukiswa Charlotte*
67. Lazarus Tshokolo Swarts - 830506 5787 08 2 - Department of Home Affairs, Private Bag X077, Vereeniging, 1930 - *Lazarus Kgopolo*
68. Tshifhwa Mubva - 870302 1313 08 6 - Department of Home Affairs, Private Bag X1016, Dzanani, 0955 - *Tshifhwa*
69. Tshediso Ebenezer Mokwena - 890628 5201 08 3 - Department of Home Affairs, Private Bag X2012, Krugersdorp, 1754 - *Tshepiso*
70. Grace Tshogohatso Lekwene - 770916 0877 08 9 - PO Box 404, , Taung Station, 8580 - *Grace Tshogohatso*
71. Ntombovuyo Tiya - 740821 0735 08 8 - Department of Home Affairs, Private Bag X109, Pretoria, 0001 - *Ntombovuyo Nobom*
72. Hoshiana William Khobana - 420926 5500 08 5 - Department of Home Affairs, Private Bag X01010, Phalaborwa, 1390 - *Hoshani William*
73. Nozokiso Ntshantshe Ntshuntshe - 881209 0706 08 6 - Department of Home Affairs, Private Bag X04, Wibsey, 1717 - *Nozokiso*
74. Jaska Maluleke - 861021 5531 08 6 - Department of Home Affairs, Private Bag X077, Vereeniging, 1930 - *Mzamani Jaska*
75. Nopinki Mawonga - 540714 0185 08 5 - Department of Home Affairs, Private Bag X1216, Confimvaba, 5380 - *Nopinki Deborah*
76. Vinolia Palesa Agrinate Seleka - 880822 0872 08 7 - Department of Home Affairs, Private Bag X26, Rosslyn, 0200 - *Palesa Vinolia Agrinett*
77. Kedisaletse Tslislofelo Mafa - 870429 1061 08 2 - Department of Home Affairs, Private Bag X109, Pretoria, 0001 - *Tsholofelo Kedisaletse*
78. Leaners Kgalagadise Mashabela - 870405 5374 08 5 - Department of Home Affairs, Private Bag X71, Lebowakgomo, 0737 - *Kgalagadise Leaners*
79. Modiegi Joseph Simelane - 740801 0518 08 0 - Department of Home Affairs, Private Bag X2012, Krugersdorp, 1740 - *Modiegi Josephine*
80. Mabaeng Lisbeth Nkomo - 890414 0398 08 7 - Department of Home Affairs, Private Bag X18, Bethlehem, 9700 - *Nobayeni Lisbeth*
81. Mildred Nhlapo - 490625 0571 08 4 - Department of Home Affairs, Private Bag X11, Johannesburg, 2000 - *Mildred Nombuyiselo*
82. Sifiso Deves Chauke - 880802 5854 08 2 - 4728 Extension 23, Mzinoni, Bethal, 2310 - *Sifiso Deves*
83. Melda Nthabiseng Malapane - 831218 0506 08 2 - Department of Home Affairs, Private Bag X605, Pretoria, 0001 - *Mathabo Mankwane*
84. Mpondokazi Celu - 820627 0638 08 8 - Department of Home Affairs, Private Bag X9003, East London, 5200 - *Mpondokazi Melissa*
85. Paulina Mokgetlele Matome - 880903 0932 08 7 - Department of Home Affairs, Private Bag X2018, Oberholzer, 2502 - *Letang*
86. Nozipiwo Saliwane - 860803 0418 08 3 - Department of Home Affairs, Private Bag X7489, King Williams Town, 5600 - *Nosipiwo*
87. Motlalenioa Joseph Lebeta - 700208 5909 08 2 - Department of Home Affairs, Private Bag X5, Randfontein, 1760 - *Motlalenioa Joseph*
88. Mmaherman Lady Melk - 140714 0243 08 6 - Department of Home Affairs, Private Bag X82064, Rustenburg, 0300 - *Mmaherman Leta*
89. Noluphatho Buje - 830205 1028 08 4 - Department of Home Affairs, Private Bag X5006, Umtata, 5100 - *Noluphatho Nokhanyiso*
90. Shane Mosia - 751010 0508 08 5 - Department of Home Affairs, Private Bag X077, Vereeniging, 1930 - *Puleng Shane*
91. Thusile Kleinbooi Meyers - 751122 5567 08 9 - Department of Home Affairs, Private Bag X332, De Aar, 7000 - *Thusile*
92. Gadihele Vivian Galeitsiwe-Miah - 870104 0696 08 5 - Department of Home Affairs, Private Bag X332, De Aar, 7000 - *Ahysha Khatun*
93. Siphoh Buta - 881212 6041 08 6 - Department of Home Affairs, Private Bag X5001, Brits, 0250 - *Emmanuel Siphoh*
94. Grace Matlou - 750126 0389 08 5 - Department of Home Affairs, Private Bag X605, Pretoria, 0001 - *Modjadji Grace*

95. Nzuzo Rolland Zazini - 420113 5513 08 3 - Department of Home Affairs, Private Bag X7489, King Williams Town, 5600 - *Nzuzo Raymond*
96. Beauty Kgadi Mahlase - 760303 1413 08 5 - Department of Home Affairs, Private Bag X021, Benoni, 1500 - *Mongatane Bernice*
97. Sinma Maria Kgafela - 850122 0529 08 4 - Department of Home Affairs, Private Bag X1053, Temba, 0407 - *Sinah Maria*
98. Thobeka Lydia Nkewana - 750416 0840 08 2 - Department of Home Affairs, Private Bag X3081, Worcester, 6849 - *Nokuphumla Lycia*
99. Nongaziwa Vivian Buda - 770505 0655 08 0 - Department of Home Affairs, Private Bag X3081, Worcester, 6849 - *Vivian*
100. Motete James Matake - 720614 5990 08 7 - Department of Home Affairs, Private Bag X920, Potchefstroom, 2520 - *Matake Motete*
101. Rahlabi Mehlape - 770301 5571 08 8 - Department of Home Affairs, Private Bag X9426, Polokwane, 0700 - *Rahlabi Fish*
102. Nosipho Bertha Dumefile - 581010 1402 08 6 - Department of Home Affairs, Private Bag X6332, Engcobo, 5050 - *Nomzi Nosipho Bertha*
103. Nombulelo Pricilla Kani - 560318 0861 08 6 - Department of Home Affairs, Private Bag X7489, King Williams Town, 5600 - *Nomvano Priscilla*
104. Moyahabo Roslina Rampedi - 691217 0401 08 7 - PO Box 5097, , Mokgwati, 0861 - *Moyagabo Roseline*
105. Makhampepe David Ganso - 681112 5362 08 1 - Department of Home Affairs, Private Bag X6030, Port Elizabeth, 6001 - *David*
106. Phuti Phillis Ngoepe - 860214 1140 08 2 - Department of Home Affairs, Private Bag X605, Pretoria, 0001 - *Phuti Meldah*
107. Louise Biko - 850426 0325 08 2 - Department of Home Affairs, Private Bag X2, Khayelitsha, 7793 - *Zanele*
108. Muhla Siyanda Sihle Mbatha - 861115 5707 08 2 - PO Box 143, , Hlabisa, 3937 - *Muhle Sihle*
109. Mohlophehi Bennett Mtuzi - 850316 5283 08 1 - Department of Home Affairs, Private Bag X05, Vanderbijlpark, 1900 - *Prince Tebogo*
110. Dolphe Mathebula - 830808 0842 08 0 - Department of Home Affairs, Private Bag X2002, Hazyview, 1242 - *Dolphy Euthelia*
111. Nkhane Maria Louw - 830418 0546 08 5 - Department of Home Affairs, Private Bag X551, Taung, 8584 - *Granny*
112. Grace Tshanyane Bojong - 870527 0528 08 2 - Department of Home Affairs, Private Bag X551, Taung, 8584 - *Boitshoko Grace*
113. Ngqeleni Mendu - 740605 6312 08 7 - Department of Home Affairs, Private Bag X54333, Durban, 4000 - *Sandile Ngqeleni*
114. Bongumsa Makhunga - 860323 6120 08 8 - Department of Home Affairs, Private Bag X41, Roodepoort, 1725 - *Bongumusa Khulekani*
115. Sello Johannes Niheng - 701216 5523 08 3 - Department of Home Affairs, Private Bag X1054, Germiston, 1400 - *Sico Sello Johannes*
116. Sipho Aron Babili - 840908 6095 08 5 - Department of Home Affairs, Private Bag X71, Lebowakgomo, 0737 - *Sipho Aaron*
117. Merriam Seleka Sokho - 850331 0703 08 2 - Department of Home Affairs, Private Bag X1, Soshanguve, 0152 - *Merriam Phina*
118. Thankga Maria Mchunu - 620603 1231 08 4 - Department of Home Affairs, Private Bag X1, Soshanguve, 0152 - *Maria*
119. Zamani Thabani Mngadi - 850713 5921 08 4 - Department of Home Affairs, Private Bag X9005, Pinetown, 3600 - *Thabani Zamani*
120. Matshupe malebasidney Nkadimeng - 741128 5399 08 7 - Department of Home Affairs, Private Bag X605, Pretoria, 0001 - *Matshupe Malebo Sidney*
121. Nokukhanya Evidance Mngadi - 820915 1224 08 5 - Department of Home Affairs, Private Bag X823, Port Shepstone, 4240 - *Nokukhanya Evidence*
122. Fakazile Angel Mantengu - 820914 0574 08 7 - Department of Home Affairs, Private Bag X35, Eshowe, 3815 - *Nokwazi Angel*
123. Magcinela Daphney Nkosi - 770616 0294 08 3 - Department of Home Affairs, Private Bag X35, Eshowe, 3815 - *Bagcinele Daphney*
124. Mduduzi Albert Ntuli - 830511 5450 08 7 - Department of Home Affairs, Private Bag X1006, Edenvale, 1610 - *Mduduzi*
125. Doctor Seluma - 810904 6063 08 8 - Department of Home Affairs, Private Bag X7209, Witbank, 1035 - *Doctor Edward*
126. Josephine Mphahlele - 770114 0351 08 7 - Department of Home Affairs, Private Bag X1006, Edenvale, 1610 - *Moloko Josephine*
127. Qondisephi Praiseworthy Zondi - 661023 0436 08 1 - Department of Home Affairs, Private Bag X12, Tongaat, 3242 - *Qondisephi Praiseworthy Nonhlanhla*

128. Maite Khutso Nkosi - 750608 0333 08 0 - Department of Home Affairs, Private Bag X1006, Edenvael, 1610 - *Maite Khutjo*
129. Nonzondelelo Mandlana - 710929 0969 08 0 - Department of Home Affairs, Private Bag X54333, Durban, 4000 - *Nonzondelelo Jessica*
130. Victoria Anna Biekie Tsoho - 810719 1017 08 9 - Department of Home Affairs, Private Bag X2018, Oberholzer, 2502 - *Victoria Mmalokisang*
131. Xidyohi John Ntlemo - 770515 5336 08 1 - Department of Home Affairs, Private Bag X2249 Sibasa, Venda, 0970 - *Mulalo John*
132. Noni Makaya - 630819 0832 08 0 - 1537 NU 17, , Mdantsane, 5219 - *Charmaine Noni*
133. Angel Mokoena - 850609 0039 08 0 - Department of Home Affairs, Private Bag X26, Rosslyn, 0200 - *Angel Mphifi*
134. Kholofelo Mohale - 870806 5611 08 9 - Department of Home Affairs, Private Bag X4007, Tzaneen, 0850 - *Kholofelo Cassius*
135. Petrus Seyheyi Dassie - 840506 5218 08 6 - Department of Home Affairs, Private Bag A7, Klerksdorp, 2570 - *Petrus Sithethi*
136. Ludumo Hina - 760108 5384 08 7 - Department of Home Affairs, Private Bag X9003, East London, 5200 - *Lindela Ludumo Tandile*
137. Zwelihle Hlabe - 801222 5962 08 0 - Department of Home Affairs, Private Bag X54333, Durban, 4000 - *Mnezi Innocent*
138. Petrus Mphanama Ramothibe - 851230 5998 08 6 - Department of Home Affairs, Private Bag X11, Boksburg, 1460 - *Petrus Mphanama Kagiso*
139. Happy Mathopa Malapile - 860926 6594 08 4 - Department of Home Affairs, Private Bag X11, Boksburg, 1460 - *Harry Mathopa*
140. Gertrude Mngwe - 850601 0800 08 2 - Department of Home Affairs, Private Bag X3200, Kokstad, 4700 - *Gertrude Thembeke*
141. Abram Willy Mosoma - 760228 5356 08 1 - Department of Home Affairs, Private Bag X9426, Polokwane, 0700 - *Phoku Willy*
142. Moses Ncube - 741125 5809 08 1 - Department of Home Affairs, Private Bag X605, Pretoria, 0001 - *Moses Billy*
143. Conrad Jaco Van Der Riet - 801202 5120 08 7 - 8 Whitney Avenue, Fernglen, Port Elizabeth, 6045 - *Conrad Riaan Nico*
144. Kwezi Moiteka - 760829 5594 08 2 - Department of Home Affairs, Private Bag X432, Qumbu, 5180 - *Kwezi Cornelius*
145. Martin Antony Brink - 860308 5321 08 4 - 10 Browning Street, , Observatory, 7925 - *Maruwaan*
146. Velaphi Cromwell Mampuru - 740624 5463 08 0 - Department of Home Affairs, Private Bag X2, Brakpan, 1540 - *Velokuhle Cromwell*
147. Sakela Elizabeth Mabaso - 710112 0724 08 2 - Department of Home Affairs, Private Bag X077, Vereeniging, 1930 - *Sakhile Elizabeth*
148. Ramatumakunye Samuel Tumahule - 711219 5601 08 9 - Department of Home Affairs, Private Bag X077, Vereeniging, 1930 - *Samuel Ramatumakunye*
149. Ayanda Andrinah Nxumalo - 870613 0231 08 1 - Department of Home Affairs, Private Bag X9922, Ladysmith, 3370 - *Ayanda Wandile*
150. Ntombizile Mkhize - 770109 0343 08 4 - Department of Home Affairs, Private Bag X5604, Greytown, 3250 - *Ntombizile Promise*
151. Bukekile Mteshana - 890921 0639 08 8 - Department of Home Affairs, Private Bag X24, Harding, 4680 - *Unathi Fundisiwe Bukekile*
152. Matshidiso Shantain Mokhonwana - 871018 0699 08 0 - Department of Home Affairs, Private Bag X11, Johannesburg, 2000 - *Matshidiso Chantal*
153. Jacqueline Abrahams - 650201 0211 08 3 - Department of Home Affairs, Private Bag X5, Mitchells Plain, 7789 - *Tasneem*
154. Zane Luckie Oelofse - 870310 5236 08 8 - Department of Home Affairs, Private Bag X59254, Karenpark, 0118 - *Zane Luka*
155. Kasinie Perumal Nicholas - 741009 0055 08 2 - Department of Home Affairs, Private Bag X14405, Lyttelton, 0140 - *Kasinie*
156. Dougal Joseph - 620407 5250 08 6 - Department of Home Affairs, Private Bag X5511, Scottburgh, 4180 - *Themba Dougal*
157. Ernest Jacobus Wentzel - 420611 5044 08 2 - PO Box 177, , L'Agulhas, 7287 - *Ernst Jacobus*
158. Kistamma Kistamma - 481215 0025 08 2 - Department of Home Affairs, Private Bag X09, Durban, 4023 - *Beena*
159. Grace Erika Greeff - 670224 0135 08 2 - South African Consulate General, C/o 265 N Gilbert Road Apt 1095 Mesa AZ, USA, 85203 - *Karensa Maloyra*
160. Christoffel Barend Phillips - 470315 5100 08 9 - Department of Home Affairs, Private Bag A7, Klerksdorp, 2570 - *Christopher Bernard*

161. Carla patricia Dos Santos Boavida De Castro - 741215 0207 08 2 - Department of Home Affairs, Private Bag X1054, Germiston, 1400 - *Carla Patricia Boavida*
162. Elizabeth Margaret Owies - 701114 0119 08 2 - 8 Engelbrecht Street, Oosterville, Upington, 8801 - *Lily Elizabeth*
163. Kenenth Frederick Knight - 700223 5233 08 6 - Department of Home Affairs, Private Bag X1006, Edenvale, 1610 - *Kenneth Frederick*
164. Levina Mildred Fredricks - 730703 0134 08 6 - Department of Home Affairs, Private Bag X5, Mitchells Plain, 7789 - *Laeeka*
165. Ockert Corneleus Vermeulen - 710810 5141 08 3 - Department of Home Affairs, Private Bag X265, Vredenal, 8160 - *Ockert Cornelius*
166. Shelly-Lynn Topham - 620524 0072 08 1 - Department of Home Affairs, PO Box 14405, Lyttelton, 0140 - *Shelly*
167. Maria Gertruida Westley - 710627 0236 08 4 - Department of Home Affairs, Private Bag X3009, Randburg, 2125 - *Maria Helen*
168. David mark De Bruyn - 620926 5278 08 6 - Department of Home Affairs, Private Bag X5, Mitchells Plain, 7789 - *Mogamad-Mujuid*
169. Mark Von Willingh - 711013 5497 08 9 - 48 Ebro Street, Eindhoven, Delft, 7100 - *Muneeb*
170. Katjie Karools - 641016 0204 08 2 - Department of Home Affairs, Private Bag X1054, Germiston, 1400 - *Katie*
171. Jairam Naidoo Naidoo - 540903 5102 08 4 - 43 Newlyn Road, Allandale, Pietermaritzburg, 3201 - *Jairam*
172. Muniamah Vijaylaxmi Maduray - 550830 0207 08 8 - Department of Home Affairs, Private Bag X10661, Kwa Dukuza, 4450 - *Muniamah Vijayalaxmi*
173. Daniel Tinker - 560702 5173 08 6 - Department of Home Affairs, Private Bag X74, Bellville, 7535 - *Rodney*
174. Gnanasagaren Narainsamy - 560820 5092 08 8 - Department of Home Affairs, Private Bag X9005, Pinetown, 3600 - *Lenny*
175. Anthony Botha - 590130 5143 08 7 - Department of Home Affairs, Private Bag X5, Mitchells Plain, 7785 - *Moegamad Tougeed*
176. Imelda Solomon - 590220 0190 08 2 - Department of Home Affairs, Private Bag X5, Mitchells Plain, 7789 - *Imelda Mary*
177. Irene Susan Tassiem - 590224 0184 08 7 - Department of Home Affairs, Private Bag X5, Mitchells Plain, 7789 - *Ilhaam*
178. Sharon Margaret Lloyd - 630121 0645 08 7 - Department of Home Affairs, Private Bag X5001, Brits, 0250 - *Sharai Margaret*
179. Rachel Doreen Nayager - 580507 0188 08 8 - Department of Home Affairs, Private Bag X54333, Durban, 4000 - *Devesha Saimiksha*
180. Karools Claasen - 720924 5117 08 0 - Department of Home Affairs, Private Bag X3028, Paarl, 7600 - *Kaydin*
181. Diana Botes - 721031 0067 08 5 - Department of Home Affairs, Private Bag X74, Bellville, 7535 - *Zoë*
182. Bahiyya Rose - 740717 0092 08 4 - Department of Home Affairs, Private Bag X1006, Edenvale, 1610 - *Berenice Bernadette*
183. Anthony Martin - 540402 5037 08 5 - Department of Home Affairs, Private Bag X5, Mitchells Plain, 7789 - *Anwar*
184. Sharon Dawn Levy - 660402 0181 08 0 - Department of Home Affairs, Private Bag X 11, Wynberg, 7824 - *Shereen*

**DEPARTMENT OF JUSTICE AND CONSTITUTIONAL DEVELOPMENT
DEPARTEMENT VAN JUSTISIE EN STAATKUNDIGE ONTWIKKELING**

No. 218

29 February 2008

SMALL CLAIMS COURTS ACT, 1984 (ACT NO. 61 OF 1984)

**ESTABLISHMENT OF A SMALL CLAIMS COURT FOR THE AREA OF
SEKGOSESE**

I, Johannes Hendrik de Lange, Deputy Minister for Justice and Constitutional Development, acting under the power delegated to me by the Minister for Justice and Constitutional Development, under section 2 of the Small Claims Courts Act, 1984 (Act No. 61 of 1984), hereby-

- (a) establish a small claims court for the adjudication of claims for the area of Sekgosese, which consists of the district of Sekgosese;
- (b) determine Morebeng to be the seat of the said court; and
- (c) determine Morebeng to be the place in that area for the holding of sessions of the said court.



**J H DE LANGE
DEPUTY MINISTER FOR JUSTICE
AND CONSTITUTIONAL DEVELOPMENT**

No. 218

29 Februarie 2008

WET OP HOWE VIR KLEIN EISE, 1984 (WET NO. 61 VAN 1984)**INSTELLING VAN 'N HOF VIR KLEIN EISE VIR DIE GEBIED SEKGOSESE**

EK, Johannes Hendrik de Lange, Adjunk-Minister van Justisie en Staatkundige Ontwikkeling, handelende onderste kragtens gedelegeerde na my van die Minister van Justisie en Staatkundige Ontwikkeling, handelende kragtens artikel 2 van die Wet op Howe vir Klein Eise, 1984 (Wet No. 61 van 1984) –

- (a) stel hierby 'n hof vir klein eise in vir die beregting van eise vir die gebied Sekgosese bestssnde uit die distrik Sekgosese.
- (b) bepaal hierby Morebeng as die setel van genoemde hof; en
- (c) bepaal hierby, Morebeng as die plek in daardie gebied vir die hou van sittings van genoemde hof.



J H/DE LANGE
ADJUNK MINISTER VAN JUSTISIE
EN STAATKUNDIGE ONTWIKKELING

No. 219

29 February 2008

SMALL CLAIMS COURTS ACT, 1984 (ACT NO. 61 OF 1984)**ESTABLISHMENT OF A SMALL CLAIMS COURT FOR THE AREA OF MUSINA**

I, Johannes Hendrik de Lange, Deputy Minister for Justice and Constitutional Development, acting under the power delegated to me by the Minister for Justice and Constitutional Development, under section 2 of the Small Claims Courts Act, 1984 (Act No. 61 of 1984), hereby-

- (a) establish a small claims court for the adjudication of claims for the area of Musina, which consists of the district of Messina;
- (b) determine Musina to be the seat of the said court; and;
- (c) determine Musina to be the place in that area for the holding of sessions of the said court.



J H DE LANGE
DEPUTY MINISTER FOR JUSTICE
AND CONSTITUTIONAL DEVELOPMENT

No. 219

29 Februarie 2008

WET OP HOWE VIR KLEIN EISE, 1984 (WET NO. 61 VAN 1984)**INSTELLING VAN 'N HOF VIR KLEIN EISE VIR DIE GEBIED MUSINA**

Ek, Johannes Hendrik de Lange, Adjunk-Minister vir Justisie en Staatkundige Ontwikkeling, handelende kragtens die bevoegheid aan my gadeleeger deur die Minister vir Justisie en Staatkundige Ontwikkeling, kragtens artikel 2 van die Wet op Howe vir Klein Eise, 1984 (Wet No. 61 van 1984) –

- (a) stel hierby 'n hof vir klein eise in vir die beregting van eise vir die gebied Musina bestaande uit die distrik Messina;
- (b) bepaal hierby Musina as die setel van genoemde hof; en
- (c) bepaal hierby Musina as die plek in daardie gebied vir die hou van sittings van genoemde hof.



J H DE LANGE
ADJUNK-MINISTER VIR JUSTISIE
EN STAATKUNDIGE ONTWIKKELING

**DEPARTMENT OF TRADE AND INDUSTRY
DEPARTEMENT VAN HANDEL EN NYWERHEID**

No. 224

29 February 2008

STANDARDS ACT, 1993

**AMENDMENT TO THE COMPULSORY SPECIFICATION FOR VEHICLES
OF CATEGORY O3 AND O4**

I, Mandisi Mpahlwa, Minister of Trade and Industry, hereby under Section 22(1)(a)(i) of the Standards Act, 1993 (Act No. 29 of 1993), and on the recommendation of the Council of the South African Bureau of Standards, withdraw the current Compulsory Specification for *vehicles of category O3 and O4*, and replace it with the Compulsory Specification as set out in the attached schedule, with effect from the date two (2) months from of publication of this notice.

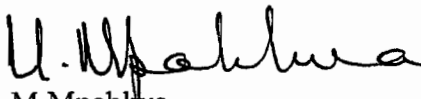
M Mpahlwa
Minister of Trade and Industry

SCHEDULE

COMPULSORY SPECIFICATION FOR VEHICLES OF CATEGORY O₃ AND O₄

1 Scope

1.1 This specification covers the requirements for vehicles of category O₃ and O₄ designed or adapted for the conveyance of goods and for operation on a public road, including any category O₃ and O₄ vehicle not previously registered in South Africa.

NOTE New vehicles of category O₃ and O₄ designed and constructed for the purpose of the carriage of passengers, as in a semi-trailer bus, are also subject to the relevant requirements for category M₂ and M₃ motor vehicles (buses).

1.2 The requirements of the specification shall, in so far as the parts already incorporated are concerned, apply in respect of an incomplete vehicle supplied for further manufacture by one manufacturer to another, and the entire specification shall apply to the vehicle after completion thereof by the last-mentioned manufacturer.

1.3 The specification does not apply to experimental or to prototype trailers constructed or imported by the original manufacturer or by importers for the purpose of testing, assessment or development, or to those military trailers that embody ordnance or missile systems, or to agricultural trailers.

1.4 The relevant requirements of this specification that take effect on any specified date, shall not apply to vehicles manufactured or imported before that date.

1.5 Homologation shall comprise the confirmation by the Regulatory Authority that the manufacturer has provided the Regulatory Authority with the following specific evidence in respect of the commodity covered by this compulsory specification:

- a) a summary of evidence showing that all relevant tests have been conducted with successful results under appropriate controls in respect of the model or the type of the commodity;
- b) sufficient data to enable a relevant model or type and its components to be identified and related to (a) above;
- c) relevant samples for the conducting of whatever tests and inspections are considered appropriate by the Regulatory Authority, to verify any or all of the evidence provided;
- d) details of the quality management system applied by the manufacturer;
- e) when relevant, documentation to advise subsequent manufacturers of incomplete commodities of their responsibilities; and
- f) agreement by the manufacturing source, to permit conformity of production audits to be carried out by the Regulatory Authority at the relevant manufacturing, assembling and test facilities.

The Regulatory Authority may issue such confirmation, on application, in respect of new models or types, provided that such confirmation may not be used for the purpose of advertising or to imply that all units of the commodity necessarily or consequently comply with all the requirements of this specification.

1.6 Where an SABS standard, including an international standard, or an ECE regulation adopted by the SABS, is incorporated by reference into this specification, only the technical requirements/specification for the commodity, and the tests to verify the compliance, apply.

2 Definitions

For the purposes of this specification, the following definitions apply:

2.1

agricultural trailer

a low speed trailer designated as such by the manufacturer, and intended to be towed by a vehicle that does not exceed 40 km/h

2.2

category O:

a) category O₃

trailers with a maximum mass exceeding 3,5 metric ton but not exceeding 10 metric ton; and

b) category O₄

trailers with a maximum mass exceeding 10 metric ton

Semi-trailers and centre-axle trailers.

In the case of a semitrailer or a centre-axle trailer, the maximum mass to be considered for classifying the trailer shall be the static vertical load transmitted to the ground by the axle or axles of the semitrailer or centre-axle trailer when coupled to the towing vehicle and carrying its maximum load

2.3.

manufacturer

the person who manufactures, produces, assembles, alters, modifies, adapts or converts a new category O vehicle, and "manufacture" has a corresponding meaning

2.4

maximum weight

the maximum mass of a vehicle and its load as specified by the manufacturer

2.5

model

the manufacturer's description for a series of vehicle designs that do not differ in respect of axle configuration and does not exceed the trailer's gross axle mass load.

The Regulatory Authority reserves the right to decide on which variations or combinations of variation constitute a new model, and may also take cognisance to the classification system applied in the country of origin of the design

2.6

public road

a road, street or thoroughfare, including the verges, or any other place, whether a thoroughfare or not, to which the public have the right of access and that they commonly use

2.7

regulatory authority

an organization appointed by the Minister of the Department of Trade and Industry to implement this compulsory specification on behalf of the South African Government

2.8

semi-trailer bus

a category O semi-trailer, that is intended to be drawn by a category N truck-tractor, the combination of which is designed or adapted for the conveyance of a driver and more than eight passengers. (See also 3.3.)

3 General requirements

3.1 Requirements for lights, lighting equipment and rear warning signs

3.1.1 Lights

Lights fitted to a trailer shall comply with the relevant requirements as given in the following:

SABS ECE R3, *Uniform provisions concerning the approval of retro-reflecting devices for power driven vehicles and their trailers;*

SABS ECE R4, *Uniform provisions for the approval of devices for the illumination of rear registration plates of motor vehicles (except motorcycles) and their trailers;*

SABS ECE R6, *Uniform provisions concerning the approval of direction indicators for motor vehicles and their trailers;*

SABS ECE R7, *Uniform provisions concerning the approval of front and rear position (side) lamps, stop-lamps and end outline marker lamps for motor vehicles (except motor cycles) and their trailers;*

SABS ECE R23, *Uniform provisions concerning the approval of reversing lights for power driven vehicles and their trailers;*

SABS ECE R37, *Uniform provisions concerning the approval of filament lamps for use in approved lamp units of power driven vehicles and trailers;* and

SABS ECE R91, *Uniform provisions concerning the approval of side-marker lamps for motor vehicles and trailers.*

3.1.2 Lighting and retro-reflectivity

Lighting and retro-reflective markings shall be fitted to a trailer and shall comply with the relevant requirements given in SABS ECE R48, *Uniform provisions concerning the approval of vehicles with regard to the installation of lighting and light-signalling devices* and SABS ECE R104, *Uniform provisions concerning the approval of retro-reflective markings for heavy and long vehicles and their trailers.*

The requirements for the installation of retro-reflectors may be met by the use and fitting of retro-reflectors that are defined in the relevant regulations of the Road Traffic Act, 1989 (Act 29 of 1989), or the National Road Traffic Act 1996 (Act 93 of 1996) and in addition, the requirements may also be met by the use and fitting of retro-reflectors that are integral portions of any other light lens assembly.

3.1.3 Rear warning sign (chevrons)

A rear warning sign shall be fitted to a trailer and shall comply with the relevant requirements of the Road Traffic Act, 1989 (Act 29 of 1989) or the National Road Traffic Act, 1996 (Act 93 of 1996).

3.2 Requirements for windows and partitions

3.2.1 Glass partitions and windows fitted to any trailer shall be:

- a) of safety glass that complies with the relevant requirements given in SABS 1191, *Safety glass for vehicles – High penetration resistant laminated safety glass for vehicles*, SABS 1192, *Safety glass for vehicles – Laminated safety glass for vehicles* or SABS 1193, *Safety glass for vehicles – Toughened safety glass for vehicles*; or
- b) of plastics safety glazing material that complies with the relevant requirements of SABS 1472,

Plastics safety glazing materials for motor vehicles.

3.2.2 For the purpose of this specification, the marking requirements shall be as follows:

- a) the glass shall bear the glass manufacturer's registered trade mark; and
- b) the glass fitted shall comply with an approved national standard, recognized by the Regulatory Authority, that will provide a method of identifying the glass type.

3.3 Requirements for brakes and braking equipment

A vehicle shall be fitted with braking equipment that complies with the relevant requirements given in SABS ECE R13, *Uniform provisions concerning the approval of vehicles of categories M, N and O with regard to braking*, to the level of ECE R13.08.

For the purposes of braking requirements for a semi-trailer bus, the vehicle shall be considered as a category O commercial vehicle.

3.4 Pneumatic braking system connections

A vehicle shall be fitted with a pneumatic braking system that complies with the relevant requirements given in SABS 1477-1, *Pneumatic braking system connections between drawing and drawn vehicles – Part 1: Contact type couplings*, SABS 1477-2, *Pneumatic braking system connections between drawing and drawn vehicles – Part 2: Palm type couplings* and SABS 1477-3, *Pneumatic braking system connections between drawing and drawn vehicles – Part 3: The arrangement of connections on vehicle, using contact type or palm type couplings*.

3.5 Requirements for electrical connectors

Electrical connectors that are fitted for the purpose of towing, shall comply with:

- a) in the case of 12 V systems:
 - 1) SABS 1327, *Electrical connectors for towing and towed vehicles (7-pole connectors)*, or
 - 2) SABS ISO 11446, *Passenger cars and light commercial vehicles with 12 V systems – 13-pole connectors between towing vehicles and trailers – Dimensions and contact allocation*; and
- b) in the case of 24 V systems:
 - 1) SABS 1327, *Electrical connectors for towing and towed vehicles (7-pole connectors)*; or
 - 2) SABS ISO 12098, *Commercial vehicles with 24 V systems – 15-pole connectors between towing vehicles and trailers – Dimensions and contact allocation*.

3.6 Requirements for couplings on semi-trailers

3.6.1 Kingpin and mounting plate

A semi-trailer shall be equipped with a fifth-wheel kingpin that is securely fitted to a mounting plate on the semi-trailer.

The kingpin shall be of type 50 or type 90. The combination of the kingpin and mounting plate shall be capable of supporting the appropriate mass-load. The dimensions of a type 50 and type 90 kingpin shall comply with those given in figure 1.

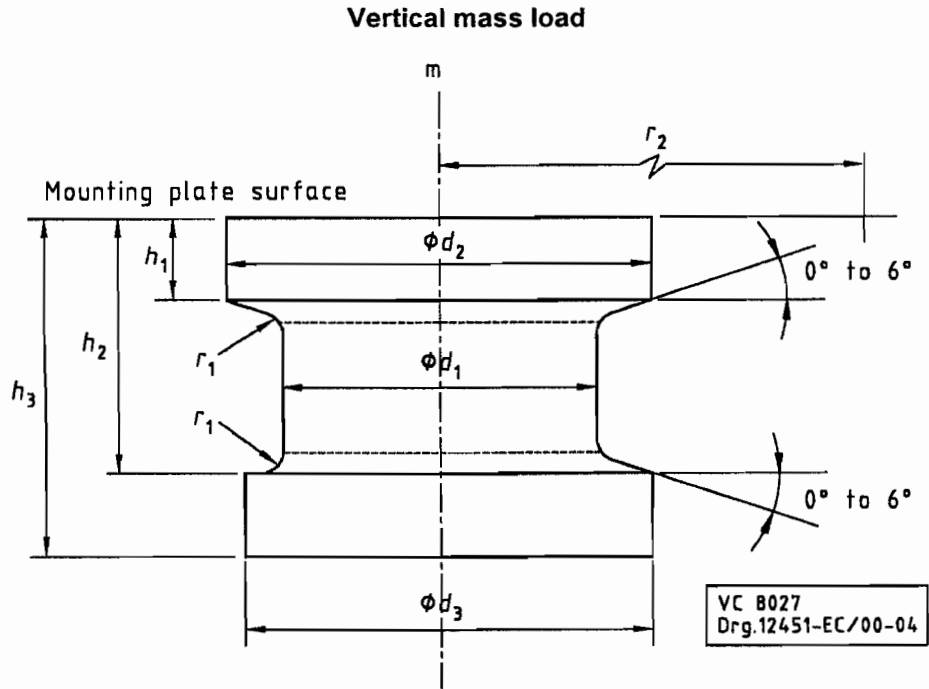

1	2	3
Parameter	Dimensions of kingpin mm	
	Type 50	Type 90
$\varnothing d_1$	50,8 ± 0,1	89,0 ± 0,1
$\varnothing d_2$	73,0 ± 0,1	114,0 ± 0,1
$\varnothing d_3$	71,5 ± 0,4	111,0 ± 0,4
h_1	35 + 0 – 3,0	21 + 0 – 3,0
h_2	70 + 1,5 – 0	59 + 1,5 – 0
h_3	84 + 0 – 1,5	74 + 0 – 2,0
Radius r_1	3,0 + 0,5 – 0	3,0 + 0,5 – 0
Radius r_2	At least 485	At least 485
	Vertical mass load tons	Vertical mass load tons
m	Not more than 20	Over 20

Figure 1 — Kingpin details

The mounting plate surface shall be flat within 1,5 mm total indicator reading (TIR) over a radius of at least 485 mm from the axis of the kingpin. The geometry of the kingpin/mounting plate combination shall be such that when the relevant gauge, shown in figure 2, is placed in contact with the mounting plate surface across any transverse diameter, the kingpin is able to pass through the gauge with the gauge still in contact with the surface.

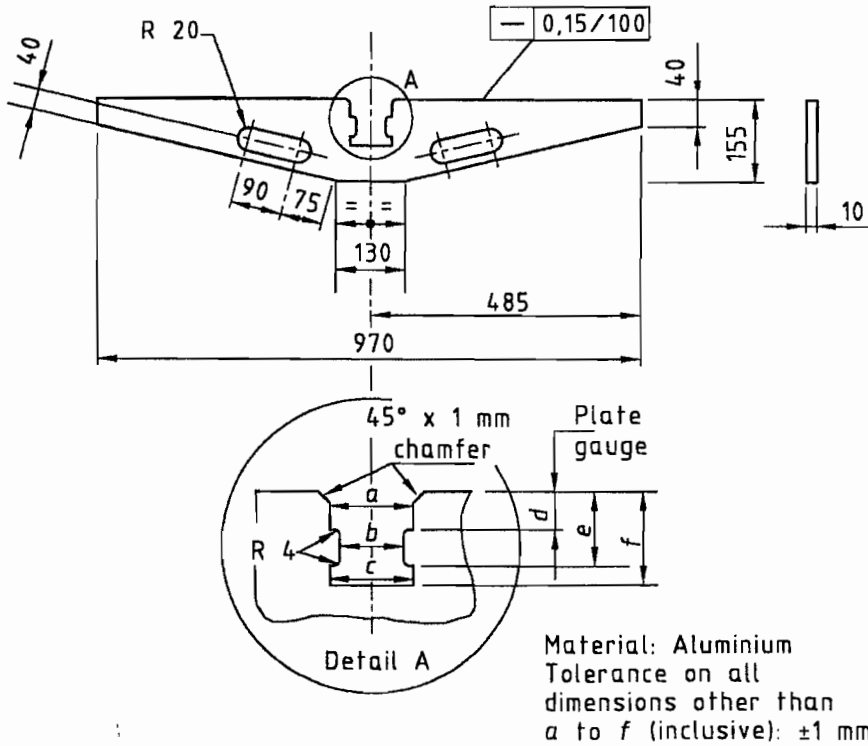

VC 8027
Drg.10194-EC/00-04

1	2	3
Parameter	Dimensions of kingpin mm	
	Type 50	Type 90
a	74,5	116,3
b	53,4	93,5
c	74,7	115,7
d	37,6	23,0
e	68,0	57,0
f	85,4	75,2

NOTE Tolerance on all above dimensions ± 0,05 mm.

Figure 2 — Details of the kingpin/mounting plate gauge

The axis of a kingpin shall, at any point on the mounting plate surface within a radius of at least 485 mm from the axis of the kingpin, be at an angle of $90^\circ \pm 1^\circ$ to the mounting plate surface.

3.6.2 Mechanical properties of kingpin

A kingpin shall have mechanical properties equal to or better than those given in table 1.

Table 1 — Mechanical properties of kingpin

1	2
Mechanical property	Value
Tensile strength, MPa	850 – 1 000
Yield stress, MPa, min.	680
Elongation, %, min.	13
Izod impact value, J, min.	54
Hardness, HB	250 – 300

3.7 Requirements for rear underrun protection devices

A rear underrun protection device shall be fitted to a trailer and shall comply with the relevant requirements given in SABS 1055, *Motor vehicle safety: Rear underrun protection devices*.

3.8 Requirements for warning triangles

In the case of a vehicle supplied with a warning triangle as part of the vehicle equipment, such a warning triangle shall comply with the requirements of SABS 1329-1, *Retro-reflective and fluorescent warning signs for road vehicles – Part 1: Triangles*.

4 Requirements concerning metrological data

4.1 Trailer dimensions

The dimensions of a trailer shall comply with the requirements of the relevant regulations of the Road Traffic Act, 1989 (Act 29 of 1989) or the National Road Traffic Act 1996 (Act 93 of 1996).

4.2 Information plates

4.2.1 Data plate

A trailer shall have, permanently affixed to it in a conspicuous position, and visible from the left-hand side of the trailer, a data plate or plates. The following information shall be legibly and permanently imprinted or stamped on the data plate(s):

- a) the gross vehicle mass, in kilograms, prefixed by the letters "GVM/BVM";
- b) the gross axle mass-load or gross axle unit mass-load of each axle or axle unit, in kilograms, prefixed by the letters "GA/BA" or "GAU/BAE", as applicable;
- c) if the trailer is a semi-trailer, the gross kingpin mass-load in kilograms, prefixed by the letters "GKM/BSM";
- d) the manufacturer's design intent, denoted by the wording "For public road operation"; and
- e) the month and the year of manufacture, denoted by four numeric digits, two for the month, followed by two for the year (for example, July 1987 would be denoted by 0787).

4.2.2 Vehicle Identification Number (VIN)

A trailer shall have a vehicle identification number that complies with the relevant requirements given in SABS ISO 3779, *Road vehicles – Vehicle identification number (VIN) – Content and structure*, and SABS ISO 4030, *Road vehicles – Vehicle identification number (VIN) – Location and attachment*.

However, the requirements for the VIN, as given in clause 5 of the said SABS ISO 4030, shall, for the purpose of this compulsory specification, be taken to read as follows:

5 VIN attachment

5.1 The VIN shall be marked directly on any integral part of the vehicle; it may be either on the frame, or, for integral frame body units, on a part of the body not easily removed or replaced.

5.2 The VIN shall also be marked on the data plate.

5.3 Deleted.

5.4 The height of the roman letters and the arabic numerals of the VIN shall be as follows:

- at least 7 mm if marked in accordance with 5.1 (frame, body, etc.) on motor vehicles and trailers; and
- at least 3 mm if marked in accordance with 5.2 (data plates).

4.3 Provision for registration

Suitable spaces shall be provided on the data plate(s) referred to in 4.2.1:

- a) T.....kg (for tare);
- b) V.....kg (for the permissible maximum trailer mass); and
- c) A.....kg or AU/AE...kg, as applicable (for the permissible axle mass-load or permissible axle unit mass-load of each axle or axle unit).

The responsibility for the marking of this information on the data plate(s) shall rest with the trailer manufacturer.

4.4 Axle brake data plates

Each axle on a trailer shall be provided with information applicable to the brake design, the particulars of which shall be permanently and legibly imprinted or stamped either on a data plate permanently affixed in a conspicuous position adjacent to the axle or on the plates as required by SABS ECE R13, given as follows:

- a) the axle make and serial number;
- b) the brake chamber size and the brake lever length;
- c) the maximum tyre size; and
- d) brake lining material type and grade.

4.5 Measuring units

All gauges, indicators or instruments that are fitted to a trailer and that are calibrated in physical units shall be calibrated in units as prescribed by the current applicable regulations promulgated under the Measuring Units and National Measuring Standards Act, 1973 (Act 76 of 1973).

5 Requirements for the control of environmental interference

5.1 Suppression of radio and television interference

All components, accessories or equipment fitted to a trailer and that generate and radiate electromagnetic energy, shall comply with the current applicable regulations relating to interference with communications, promulgated under the Telecommunications Act, 1996 (Act 103 of 1996).

5.2 Suppression of atmospheric pollution

All engines, accessories or equipment fitted to a trailer and that generate smoke emissions, shall comply with the current regulations promulgated under the Atmospheric Pollution Prevention Act, 1965 (Act 45 of 1965).

6 Requirements for trailer equipment, components and systems

6.1 Tyres

Tyres for trailers shall comply with the relevant requirements of the compulsory specification for pneumatic tyres for commercial vehicles and their trailers.

6.2 Wheel flaps

All trailers of gross mass exceeding 3,5 t shall be fitted with wheel flaps that comply with the relevant requirements given in SABS 1496, *Wheel flaps fitted to motor vehicles*.

Provided that:

chassis-only trailers that are being driven to a place to have body work fitted or to a dealer of such vehicles are excluded from the requirement for the fitment of wheel flaps.

6.3 Axle or axle unit suspension

A semi-trailer shall be fitted with axle suspension that complies with the relevant regulations of the National Road Traffic Act, 1996 (Act 93 of 1996).

7 Compliance requirements

Proof of compliance shall be provided by the manufacturer, importer or builder (MIB) to the inspectorate authority in respect of each motor vehicle model covered by the scope of this specification.

Such proof of compliance shall be made available in the English language, so that the inspectorate authority can satisfy itself that compliance has been achieved prior to any such vehicle being registered in the Republic of South Africa.

Failure to provide such proof of compliance within five working days of submitting an application for homologation to the inspectorate authority, shall constitute reasonable grounds to suspect that the motor vehicle model does not comply with the requirements of this specification.

8 Equivalent requirements

The requirements of any of the SABS standards in the appropriate parts of clause 3 of this specification shall be deemed to have been met if compliance with the listed EEC or ECE requirements given in table 2, are achieved.

SCHEDULE — Operative dates

1	2	3	4	5
Subsection	Item	Operative date	Exclusions	Exclusion expiry date
	All subclauses/items not referred to below	1 September 1992	Nil	
3.1.1	Lights to SABS ECE R3 SABS ECE R4 SABS ECE R6 SABS ECE R7 SABS ECE R23 SABS ECE R37 SABS ECE R91	1 January 2001	Nil	
3.1.2	Lighting to SABS ECE R48 Markings to SABS ECE R104	1 January 2002 1 January 2002	Nil	
3.3	Braking to SABS ECE R13	1 January 2002	Vehicle models homologated before 15 August 2003	15 February 2004
3.4	Pneumatic connections to SABS 1477	1 January 2002	Nil	
3.5	Electrical connectors to SABS ISO 11446 and SABS ISO 12098	1 January 1998	Nil	
6.3	Axle suspension to National Road Traffic Act	1 January 2002	Nil	

NOTE 1 Vehicles that comply with any SABS, ECE or EEC standard that supersedes the above-mentioned standards, shall be deemed to comply with the relevant requirements of this compulsory specification.

NOTE 2 The exclusions listed in this schedule should be read in conjunction with other exclusions that are in the body of the specification, or in any applicable SABS standard.

Table 2 — Equivalent standards that shall be deemed to comply with SABS standards

1	2	3	4	5	6	7	8	9
Equivalent standards								
Subsection	Item	SABS No.	Dated	EEC	Inclusive	ECE	Others	Remarks
3.1.1	Lights	ECE R3 ECE R4 ECE R6 ECE R7 ECE R23 ECE R37 ECE R91		76/757 76/760 76/759 76/758 77/539 76/761 76/758	97/29 97/31 89/277 97/30 97/32 89/517 97/30	R3 R4 R6 R7 R23 R37 R91		
3.1.2	Installation of lights	1046	1990	76/756	89/278	R48		
3.2	Safety glazing	1191 1192 1193	1978 1978 1978	92/22 92/22 92/22		R43 R43 R43		
3.3	Brakes and braking	ECE R13	1996			R13.08		
3.6	Rear underrun	1055	1983	70/221	81/333	R58		
6.3	Axle suspension						NRTA	
NOTE Vehicles that comply with any SABS or equivalent standards that supersedes the above-mentioned standards, may be deemed to comply with such a standard.								

No. 225

29 February 2008

STANDARDS ACT, 1993**PROPOSED WITHDRAWAL OF THE COMPULSORY SPECIFICATION FOR
ARTICLES MARKED E.P.N.S.**

It is hereby made known under section 22(1)(a)(iii) of the Standards Act, 1993 (Act No. 29 of 1993), that the Minister of Trade and Industry intends to withdraw the compulsory specification for *Articles Marked E.P.N.S.* as published by Government Notice No. 4341 of 10th March 1950.

Any person who wishes to object to the intention of the Minister to withdraw the compulsory specification concerned, shall lodge their objection in writing with the President, South African Bureau of Standards, Private Bag X191, Pretoria, 0001, on or before the date two (2) months after publication of this notice.

**M Mphahlele****Minister of Trade and Industry**

GENERAL NOTICES ALGEMENE KENNISGEWINGS

NOTICE 291 OF 2008

Date: 14 February 2008

COMPETITION COMMISSION

APPLICATION FOR AN EXEMPTION

Notice is hereby given in terms of section 10(6)(a) of the Competition Act, No. 89 of 1998, as amended ("the Act"), that the South African Airways (Pty) Ltd (herein referred to as "SAA"), a state owned company, registered in terms of the Company Act of 1973, has applied to the Competition Commission ("the Commission"), in terms of section 10(1) of the Act, for an exemption from certain provisions of Chapter 2 of the Act. SAA provides passenger air transportation services both in South Africa and internationally.

The subject matter of the application is a code share agreement which SAA entered into with Qantas Airways Limited ("Qantas"), an Australian airline which also provides passenger air transportation services globally. The agreement concerns the direct airline routes between South Africa and Australia.

It is to be noted that the Commission had previously exempted this agreement and SAA is in essence asking the Commission to consider granting an extension. In particular, SAA has requested the Commission that it be permitted to engage in the following activities with Qantas:

- Co-ordinate their activities in respect of the direct routes between South Africa and Australia.
- Divide the market by allocating territories, in terms of which SAA is to operate on the route between Johannesburg and Perth, while Qantas will service the Johannesburg / Sydney route.
- Acquire blocks of seats through a hard block arrangement, in various classes, on each other's aircraft.

The Commission found, in its previous assessments, that the agreement constitutes geographic market sharing, in contravention of section 4(1)(b) of the Act. However, the Commission granted an exemption as it was satisfied that the agreement contributes to the objectives set out in section 10(3)(b) of the Act, being the maintenance or promotion of exports [section 10(3)(b)(i)]; and a change in productive capacity necessary to stop decline in an industry [section 10(b)(3)(iii)].

SAA therefore seeks an extension for a further 3 (three) year period.

Notice is further hereby given, as required by section 10(6)(b) of the Act, to allow interested parties to make written representations as to why the exemption should not be granted. Interested parties have 20 business days from the date of this notice to submit their representations to the Commission.

Such representations should be directed to:

Mr Shadrack Rambau
Competition Commission of SA
Enforcement and Exemptions Division,
Private Bag X23,
Lynnwood Ridge, 0040
Facsimile: (012) 394 4263
Email: shadrack@compcom.co.za

In correspondence kindly refer to the following case number: **2007Oct3311**.

NOTICE 292 OF 2008

CORRECTIONAL NOTICE IN TERMS OF THE RESTITUTION OF LAND RIGHTS ACT, 1994 (ACT No. 22 OF 1994), REPLACING NOTICE 1052 OF 2005 GAZETTE NO 27735

Notice is hereby given in terms of Section 11(1) of the Restitution of Land Rights Act, 1994 (Act No. 22 of 1994), as amended. These claims for the restitution of land rights have been submitted to the Regional Land Claims Commissioner for the Western Cape. The particulars regarding these claims are as follows:

Reference	Claimant Initial & Surname	Property Description	Extent (sqm)	Capacity	Deeds of Transfer	Current Owner	Date submitted
KRK6/2/3/A/1/0/17941/29 (L202)	Mrs E. Lasker	Erf 8544 Parow – subsequently consolidated into erf 18027 Parow	496 m ²	Owner	T14686/1967 T8365/1977	Housing Development Board – Western Cape: T65762/2000	97/03/06

The Commission on Restitution of Land Rights will investigate these claims in terms of provisions of the Act in due course. Any party who has an interest in the above-mentioned land is hereby invited to submit, within 60 days from the publication of this notice, any comments / information to:

The Regional Land Claims Commission: Western Cape
 Private Bag X9163
 Cape Town
 8000
 Tel: 021*426-2930
 Fax: 021*424-5146

B. Jansen

Regional Land Claims Commissioner

APPROVED 

DATE 18/01/08

CHECKED 

DATE 14/01/2008

NOTICE 293 OF 2008

GENERAL NOTICE IN TERMS OF RESTITUTION OF LAND RIGHTS ACT, 1994 [ACT 22 OF 1994] AS AMENDED

Notice is hereby given in terms of Section 11[1] of the Restitution of the Land Rights Act 1994 [Act 22 of 1994] as amended, that a claim for Restitution of Land Rights has been lodged on the properties mentioned hereunder situated in Mbombela Local Municipality in the Mpumalanga Province.

Property Description	Name of Claimant	Identity Number	KRP
Kingston Vale 125 JU	• Mr. Mantetewusha Lucas Mathebula	• 5703275572083	• 10913
	• Mr. Mbutho Abel Mathebula	• 590435542089	• 2044
	• Mr. July Komane Mayela	• 2507055160081	• 11477

CURRENT PARTICULARS OF THE PROPERTIES

1. KINGSTON VALE 125 JU

Description of property	Current Owner of Property	Title Deed Number	Extent of Property	Bond	Bond Holder	Other Endorsement
The Remaining extent of Portion 1	Municipality of Nelspruit	T37523/1976	78.6522 ha	None	None	<ul style="list-style-type: none"> ▪ K2617/1975S ▪ VA529/1983 – 2617/75S
The Remaining Extent of Portion 2	New Kingston Vale D Pty Ltd [197000572107]	T5839/2002	102.7258 ha	B3465/2002	None	<ul style="list-style-type: none"> ▪ K208/1972S ▪ K2165/1980S ▪ K347/1969S
The Remaining Extent of Portion 4	Manganese Metal Co Pty Ltd [197100660907]	T78515/1998	26.0083 ha	None	None	<ul style="list-style-type: none"> ▪ K3488/1975S ▪ K5545/1999S ▪ VA9537/2004 in favour of Manganese Metal Co Pty Ltd
The Remaining Extent of Portion 7	Freistal Family Trust [1013/1993]	T75452/1993	16.0231 ha	B99799/2007	Standard Bank of South – Africa Ltd	K2165/1980S
Portion 8	Coriander Prop Inv 5 Pty	T32313/2007	1.6490 ha	None	None	None

	Ltd [200102245607]					
Portion 9	Coriander Prop Inv 5 Pty Ltd [200102245607]	T8715/2003	3743/0000sq m	None	None	<ul style="list-style-type: none"> ▪ K208/972S ▪ K5545/1999S
Portion 10	Becker Elizabeth Louise [7311160140087]	T336829/2007	8.9936 ha	B364834/2007	Standard Bank of South - Africa Ltd	<ul style="list-style-type: none"> ▪ K2462/1986S ▪ K2821/1979S
Portion 12	Crocodile Valley Citrus Co Pty Ltd [199100123807]	T15878/1993	20.6382 ha	None	None	<ul style="list-style-type: none"> ▪ K1217/1960S ▪ VA5190/2001
Portion 13	Crocodile Valley Citrus Co Pty Ltd [199100123807]	T15878/1993	20.2626 ha	None	None	<ul style="list-style-type: none"> ▪ K1217/1960S ▪ VA5190/2001
Portion 14	Crocodile Valley Citrus Co Pty Ltd [199100123807]	T15878/1993	20.3321 ha	None	None	<ul style="list-style-type: none"> ▪ K1217/1960S ▪ VA5190/2001 in favour of Crocodile Valley Citrus Co Pty Ltd
Portion 15	Crocodile Valley Citrus Co Pty Ltd [199100123807]	T15878/1993	20.6003 ha	None	None	<ul style="list-style-type: none"> ▪ K1217/1960S ▪ VA5190/2001 in favour of Crocodile Valley Citrus Co Pty Ltd
Portion 16	Crocodile Valley Citrus Co Pty Ltd [199100123807]	T15878/1993	20.6003 ha	None	None	K2165/1980S
Portion 17	Morse Nurseries Pty Ld [1994006636007]	T78434/1997	11.1723ha	<ul style="list-style-type: none"> ▪ B41309/2006 ▪ B63405/1997 	<ul style="list-style-type: none"> ▪ Firststrand Bank Ltd ▪ Firststrand Bank Ltd 	K2165/1980S
Portion 18	Frietas Family Trust [1013/1993]	T115157/2002	10.2784ha	B99799/2007	Standard Bank of South Africa Ltd	K2165/1980S
Portion 19	Vos Familietrust	T38034/1986	11.1839ha	None	None	K2165/1980S
Portion 20	Frietas Development Pty Ltd [1988000858023]	T32312/1988	17.9872ha	B168116/2005	Standard Bank of South Africa Ltd	None
The Remaining of Portion 21	Crocodile Valley Citrus Co Pty Ltd [199100123807]	T15878/1993	66.9589ha	None	None	<ul style="list-style-type: none"> ▪ I-6225/83LG-14/11/83 ▪ K2462/1986S

						<ul style="list-style-type: none"> ▪ K812/1986S ▪ VA5190/2001 in favor of Crocodile Valley Citrus Co Pty Ltd
Portion 24	Raath Johannes Hendrik (2204125024089)	T27072/1970	21.4133ha	None	None	K2821/1979
Portion 25	All Seasons Aquatics CC (CK93/26997/23)	T20715/1995	21.4133ha	<ul style="list-style-type: none"> ▪ B18801/1996 ▪ B22456/1995 	<ul style="list-style-type: none"> ▪ Huisamen Marius Anton ▪ Boland Bank Ltd 	I-75/2008AT
Portion 26	Crocodile Valley Citrus Co Pty Ltd [199100123807]	T15878/1993	38.2441ha	None	None	<ul style="list-style-type: none"> ▪ K540/1962S ▪ VA5190/2001 in favor of Crocodile Valley Citrus Co Pty Ltd
Portion 27	<ul style="list-style-type: none"> ▪ Meyer Willem Carel (6908085256087) ▪ Meyer Elena (7407050112085) 	T119368/2006	40.2007ha	B150524/2006	Standard Bank of South Africa	<ul style="list-style-type: none"> ▪ I-4146/80C-2165/80S ▪ K2165/19880
Portion 30	Kingston Prodanne CC (CK93/90492/23)	T52368/1993	31.5859ha	B54135/1993	Nedcor Bank	None
Portion 32	Abercrombie Anna Magrietha Johanna	T39082/1992	4.3917ha	None	None	K7171/200S
Portion 33	Abercrombie Anna Magrietha Johanna	T39082/1992	13.2736ha	None	None	<ul style="list-style-type: none"> ▪ I-5015/2007LG ▪ K7171/2006S
Portion 34	<ul style="list-style-type: none"> ▪ Saldanha Brazil Andre Franklyn (5206285129084) ▪ Saldanha Lynette Doreen (5406120042084) 	T126097/2002	3.4553ha	B87816/2002	Nedcor Bank Ltd	None

Portion 35	Duvest One Pty Ltd (98/01792/07)	T135620/1998	1.8302ha	B96933/1998	Nedcor Bank Ltd	None
The Remaining extent of Portion 36	Cathedral Rock Inv 96 CC (200302432623)	T43951/2007	1.5362ha	None	None	None
Portion 37	Smit Eduard Albertus (4812135018087)	T27921/2003	2.1379ha	B59398/2005	Firststrand Bank Ltd	None
Portion 39	Great Expectation Inv 100 Pty Ltd (2002007733607)	T125943/2002	2.2797ha	B87731/2002	Absa Bank Ltd	None
Portion 40	Great Expectation Inv 100 Pty Ltd (2002007733607)	T125943/2002	2.2909ha	B87731/2002	Absa Bank Ltd	None
The Remaining extent of Portion 41	Abercrombie Anna Magrietha Johanna	T150549/2006		None	None	K7171/200S
Portion 42	Abercrombie Anna Magrietha Johanna	T39082/1992	1.9831ha	None	None	K 7171/2006S
Portion 43	Abercrombie Anna Magrietha Johanna	T39082/1992	14.7614ha	None	None	None
Portion 44	Manganese Metal Co Pty Ltd (197100660907)	T94692/1999	23.6731ha	None	None	<ul style="list-style-type: none"> ▪ K3741/2005S ▪ K5545/1999S ▪ K7171/2006S ▪ VA9536/2004 in favor of Manganese Metal Co Pty Ltd
Portion 45	Mdluli Matluli Abram (6403315315085)	T150551/2006	2.2512ha	None	None	None
Portion 46	Mdluli Mazazane Paul (5902026275085)	T150550/2006	2.1610ha	None	None	None
Portion 48	Laing Joan Anoinette (5903210103081)	T126616/2003	4.3149ha	B91395/2003	Nedcor Bank Ltd	None

2. Soetmelksvlei 118 JU [Consolidation of Ptn 2 of the Farm 125 JU]

Description of Property	Current Owner of Property	Title Deed Number	Extent of Property	Bond	Bond Holder	Other Endorsement
The Remaining extent of the Farm 118 JU	Heyneke Nicolaas Francois (4410275018007)	T19615/1975	22.0275ha	<ul style="list-style-type: none"> ▪ B45459/1996 ▪ B53185/1986 	<ul style="list-style-type: none"> ▪ Boland Bank Pks ▪ Boland 	<ul style="list-style-type: none"> ▪ K2165/1980S ▪ K347/1969S ▪ K3741/2005S

3. White Africa 120 JU [Consolidation of Ptn 11 of the Farm 125 JU]

Description of property	Current Owner of Property	Title Deed Number	Extent of Property	Bond	Bond Holder	Other Endorsement
The Remaining extent of the Farm 120 JU	Manganese Metal Co Pty Ltd (197100660907)	T58151/2002	8.5653ha	None	None	K2165/1980S

The Regional Land Claims Commissioner, Mpumalanga Province will investigate all the claims in terms of the provisions of the Act, any party interested in the above mentioned properties is hereby invited to submit within 30 [thirty days] from the date of publication of this notice any comments, or further information to:

Commissioner for Restitution of Land Rights
Private Bag X11330
Nelspruit
1200

or Home Affairs Building
3rd Floor
Corner Branders and Henshall Street
Nelspruit
1200

PHONE NO: 013 – 7558100
FAX: NO. 013 – 7523859

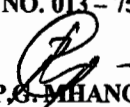
MR. P.G. MHANGWANI
COMMISSIONER FOR RESTITUTION OF LAND RIGHTS
MPUMALANGA PROVINCE
DATE: 15/02/2008

NOTICE 294 OF 2008

GENERAL NOTICE IN TERMS OF RESTITUTION OF LAND RIGHTS ACT 1994 [ACT 22 OF 1994, AS AMENDED]

Notice is hereby given in terms of Section 11[1] of the Restitution of the Land Rights [Act 22 of 1994] as amended that a land claim has been lodged by **Ms Elina Thembi Gogela [ID. No 4906150361081]** on behalf of Mabhena Family on the property mentioned hereunder situated in the **Magisterial District of Middelburg** in **Mpumalanga Province** under **Nkangala District Municipality** under reference [KRP: 834]

CURRENT PARTICULARS OF THE PROPERTY

Klipportjie 32 IS

Description of Property	Current Owner of Property	Title Deed Number	Extent of Property	Bond	Bond Holder	Other Endorsements
Portion 33	Cronje Andries Johannes (4405085055082)	T24427/1997	283.0753ha	<ul style="list-style-type: none"> • B22186/1986 • B27124/1977 • B68186/1984 • B7248/1979 • B7992/1990 	<ul style="list-style-type: none"> • Standard • Standard • Standard 	<ul style="list-style-type: none"> • K5318/1995S • K6000/1997S

The Regional Land Claims Commissioner, Mpumalanga Province will investigate all the claims in terms of the provisions of the Act, any party interested in the above mentioned property is hereby invited to submit within 30 [thirty days] from the date of publication of this notice any comments, or further information to:

Commissioner for Restitution of Land Rights

Private Bag X7201

Witbank

1035

or Hi-Tech House

23 Botha Avenue

Witbank

1035

Telephone No: 013-6903552

Fax No: 013-6902438



MR. P.G. MHANGWANI

COMMISSIONER FOR RESTITUTION OF LAND RIGHTS

MPUMALANGA PROVINCE

DATE: 15/02/2008

NOTICE 295 OF 2008

GENERAL NOTICE IN TERMS OF RESTITUTION OF LAND RIGHTS ACT, 1994 [ACT 22 OF 1994] AS AMENDED

Notice is hereby given in terms of Section 11[1] of the Restitution of the Land Rights Act 1994 [Act 22 of 1994] as amended, that a claim for Restitution of Land Rights has been lodged by Mr. Albert Mkhuzelwa Mbonani [ID. NO. 5701175627080] on behalf of Mbonani Community on the properties mentioned hereunder situated in Enkangala District Municipality in Mpumalanga Province per reference KRP 5893.

**CURRENT PARTICULARS OF THE PROPERTIES
BRAAKFONTEIN 310 IR**

Description of property	Current Owner of Property	Title Deed Number	Extent of Property	Bond	Bond Holder	Other Endorsement
The Remaining Extent of Portion 11	Boshoff Boerdery Pty Ltd [196900951007]	T21177/1973	559.4453ha	B22867/2005 B22868/2005	Standard Bank Van Suid – Afrika Ltd Alta Boshoff Voorsorg Trust	None
Portion 15	Boshoff Boerdery Pty Ltd [196900951007]	T21177/1973	85.6532 ha	B22867/2005 B22868/2005	Standard Bank Van Suid – Afrika Ltd Alta Boshoff Voorsorg Trust	<ul style="list-style-type: none"> ▪ K2599/1976S in favour of Taybard Holdings Ltd ▪ K4217/1999RM in favour of Anglo Operations Ltd
Portion 19	Van Niekerk Andries Jacobus [5412205057088]	T71462/2007	256.9596 ha	B88576/2007	Firststrand Bank Ltd	<ul style="list-style-type: none"> ▪ K1696/1981RM ▪ K1697/1981PC ▪ K2855/1980RM ▪ K3608/1977RM in favour of Meyer Charlotte ▪ K414/1959RM ▪ K4217/1999RM in favour of Anglo Operations

						Ltd
--	--	--	--	--	--	-----

The Regional Land Claims Commissioner, Mpumalanga Province will investigate all the claims in terms of the provisions of the Act, any party interested in the above mentioned properties is hereby invited to submit within 30 [thirty days] from the date of publication of this notice any comments, or further information to:

Commissioner for Restitution of Land Rights

Private Bag X7201

Witbank

1035

or High – Tech House

23 Botha Avenue

Witbank

1035

PHONE NO: 013 – 6903552

FAX NO. 013 – 6902438

MR. P.G. MHANGWANI

COMMISSIONER FOR RESTITUTION OF LAND RIGHTS

MPUMALANGA PROVINCE

DATE: 15/02/2008

NOTICE 296 OF 2008

GENERAL NOTICE IN TERMS OF RESTITUTION OF LAND RIGHTS ACT, 1994 [ACT 22 OF 1994] AS AMENDED

Notice is hereby given in terms of Section 11[1] of the Restitution of the Land Rights Act 1994 [Act 22 of 1994] as amended, that a claim for **Restitution of Land Rights** has been lodged by **Mr. Petrus Mthethwa Tshili [ID. NO. 3505295170083]** on behalf of **Msiza family** on the property mentioned hereunder situated in **Emalahleni Local Municipality in Nkangala District in the Mpumalanga Province: [KRP 5893]**

**CURRENT PARTICULARS OF THE PROPERTY
BANKFONTEIN 216 IR**

Description of property	Current Owner of Property	Title Deed Number	Extent of Property	Bond	Bond Holder	Other Endorsement
The Remaining Extent of the Farm 216 IR	Truster Boerdery Trust [2469/1994]	T13322/1998	172.0601 ha	None	None	<ul style="list-style-type: none"> ▪ I – 8710/2000C ▪ K2238/2001RM in favour of Anglo Operations Ltd ▪ K2886/1974S ▪ K3306/2004RM in favour of Side Minerals Pty Ltd ▪ K4811/1991RM in favour of Bankfontein Prop Pty Ltd ▪ K4812/1991RM in favour of African European Inv Co Ltd ▪ K4813/1991RM in favour of African European Inv Co Ltd

The Regional Land Claims Commissioner, Mpumalanga Province will investigate all the claims in terms of the provisions of the Act, any party interested in the above mentioned property is hereby invited to submit within 30 [thirty days] from the date of publication of this notice any comments, or further information to:

Commissioner for Restitution of Land Rights
Private Bag X7201
Witbank
1035

or High – Tech House
23 Botha Avenue
Witbank
1035
PHONE NO: 013 – 6903552
FAX NO. 013 – 6902438

MR. P. G. MHANGWANI
COMMISSIONER FOR RESTITUTION OF LAND RIGHTS
MPUMALANGA PROVINCE
DATE: 15/02/2008

NOTICE 297 OF 2008

AMENDING GAZETTE NOTICE NO: 987 OF 2005 AS CONTAINED IN THE GOVERNMENT GAZETTE NO: 27712 OF 2005 DATED 01 JULY 2005

AMENDMENT NOTICE IN TERMS OF SECTION 11A [4] OF RESTITUTION OF LAND RIGHTS ACT 22 OF 1994, AS AMENDED.

Notice is hereby given in terms of Section 11A[4] of the Restitution of the Land Rights 1994 [Act 22 of 1994] AS AMENDED, that the Regional Land Claims Commissioner is amending the said Gazette Notice due to the fact that Portion 1 and 2 of the Farm Witklipbank 202 IR was erroneously omitted from the said Gazette Notice. The said Gazette Notice is hereby amended to include the said portions of the farm Witklipbank 202 IR.

CURRENT PARTICULARS OF THE PROPERTIES**Witklipbank 202 IR**

Description of Property	Current Owner of Property	Title Deed Number	Extent of Property	Bond	Bond Holder	Other Endorsements
The Remaining extent of Portion 2	Danolt Boerdery CC (CK92/19230/23)	T32462/1974	96.8395ha	<ul style="list-style-type: none"> • B85575/1993 • B971077/1992 	<ul style="list-style-type: none"> • Absa Bank • Absa Bank Ltd 	<ul style="list-style-type: none"> • K1360/1994S in favour of Roetebepaling Van K648/90S • K2962/1982RM in favor of Venter Stefanus Johannes • K6216/1997S • K648/1990S • K78/1971RM
Portion 3	Danolt Boerdery CC (CK92/19230/23)	T43886/1986	153.1237ha	<ul style="list-style-type: none"> • B85575/1993 	<ul style="list-style-type: none"> • Absa Bank 	<ul style="list-style-type: none"> • I-18851/1996C

				<ul style="list-style-type: none"> • B97107/1992 	<ul style="list-style-type: none"> • Absa Bank Ltd 	<ul style="list-style-type: none"> • K1360/1994S in favor of Roetebepaling Van K648/90s • K3286/1986RM in favor of Dumas Cornelia Petronella Johanna • K6216/1997S • K648/1990S • VA2045/91-K3286/86RM in favor of Dumas Cornelia Petronella Johanna
--	--	--	--	-----------------------------------------------------------------	-------------------------------------------------------------------	---------------------------------------------------------------------------------------------------------------------------------------------------------------------------------------------------------------------------------------------------------------------------------------------------------

The Regional Land Claims Commissioner, Mpumalanga Province will investigate all the claims in terms of the provisions of the Act, any party interested in the above mentioned properties is hereby invited to submit within **30 [thirty days]** from the date of publication of this notice any comments, or further information to:

Commissioner for Restitution of Land Rights

Private Bag X7201

Witbank

1035

or High-Tech House

23 Botha Avenue

Witbank

1035

Telephone No: 013-6903552

Fax No: 013-6902438



MR. P.G MHWANGWANI

COMMISSIONER FOR RESTITUTION OF LAND RIGHTS

MPUMALANGA PROVINCE

DATE: 15/02/2008

NOTICE 298 OF 2008**GENERAL NOTICE IN TERMS OF THE RESTITUTION OF LAND RIGHTS ACT, 1994 (ACT No. 22 OF 1994)**

Notice is hereby given in terms of Section 11(1) of the Restitution of Land Rights Act, 1994 (Act No. 22 of 1994), as amended. These claims for the restitution of land rights have been submitted to the Regional Land Claims Commissioner for the Western Cape. The particulars regarding these claims are as follows:

Reference Numbers : Various
 Areas : Kensington and Athlone
 Compensation : Financial
 Number of Claimants : 3 previous owners and tenants have
 Lodged individual claims on various erven

Reference	Claimant Initials and Surname	Property Description	Extent	Capacity	Date submitted
1. KRK6/2/3/A1/0/108/56 (B474)	M N Gajuma	11 th Avenue Windomere	0	Tenant	04/04/1997
2. KRK6/2/3/A1/0/1084/110 (G273)	N.G Gqiba	11 th Avenue Kensington	0	Tenant	30/03/1998
3. KRK6/2/3/A1/0/1084/135 (J196)	SM Johannesen	Erf 21692	6573m ²	Owner	30/12/1998
4. KRK6/2/3/A1/0/1084/509 (N200)	N I Nteleri	161-8 th Avenue Kensington	0	Tenant	06/03/1997
5. KRK6/2/3/A/6/0/84/344 (S1411)	Skeyi MA	13 Beverly Street	0	Tenant	30/12/1998
6. KRK6/2/3/A/6/0/2086/20 (M82)	Roberts H.R	Erf 35232 & 35231	185 and 496m ²	Owner	05/12/1995
7. KRK6/2/3/A/6/0/2042/22 (G185)	Hampton G	Erf 44491	3005m ²	Owner	05/12/1995
8. KRK6/2/3/A/6/0/2086/61 (M2117)	Mkiva GS	15 Pine Road Rylands	0	Tenant	12/31/1998

The Regional Land Claims Commission will investigate these claims in terms of provisions of the Act in due course. Any party who has an interest in the above-mentioned land is hereby invited to submit, within 60 days from the publication of this notice, any comments / information to:

The Regional Land Claims Commission: Western Cape
 Private Bag X9163
 Cape Town
 8000
 Tel: 021 426-2930
 Fax: 021 424-5145
 Ms U. Jansen
 Regional Land Claims Commissioner

APPROVED 

DATE 

NOTICE 299 OF 2008

CORRECTIONAL NOTICE IN TERMS OF THE RESTITUTION OF LAND RIGHTS ACT, 1994 (ACT No. 22 OF 1994), REPLACING NOTICE 699 GAZETTE NO.696 OF 2006

Notice is hereby given in terms of Section 11(1) of the Restitution of Land Rights Act, 1994 (Act No. 22 of 1994), as amended. These claims for the restitution of land rights have been submitted to the Regional Land Claims Commissioner for the Western Cape. The particulars regarding these claims are as follows.

Reference	Claimant Initial & Surname	Property Description	Extent (sqm)	Capacity	Deeds of Transfer	Current Owner	Date submitted
KRK6/2/31/A/1/0/2676/70 (V230)	B. Van Niekerk	Erf 11865 Woodstock	186m ²	Owner	T123/58 T1276/66	National Housing Board T1276/66	31/12/1998

The Commission on Restitution of Land Rights will investigate these claims in terms of provisions of the Act in due course. Any party who has an interest in the above-mentioned land is hereby invited to submit, within 60 days from the publication of this notice, any comments / information to:

The Regional Land Claims Commission Western Cape

Private Bag X9163

Cape Town

8000

Tel: 021*426-2930

Fax: 021*424-5146

B. Jansen

Regional Land Claims Commissioner

APPROVED

DATE



12/11/07

CHECKED

DATE

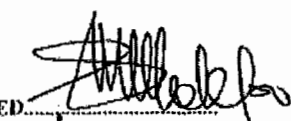

12/11/2007

NOTICE 300 OF 2008
DEPARTMENT OF LABOUR
LABOUR RELATIONS ACT, 1995

**NOTICE OF INTENTION TO CANCEL THE REGISTRATION OF AN
EMPLOYERS' ORGANISATION**

I, Johannes Theodorus Crouse, Registrar of Labour Relations, hereby, in terms of section 106(2B) give notice of my intention to cancel the registration of the **Security Industry Association of South Africa (SIASA)** for the following reasons:

- The organisation has ceased to function in terms of its constitution.
- The organisation has ceased to function as a genuine organisation as envisaged by the Act.
- The organisation is functioning for the personal gain of individuals.
- The organisation did not comply with the provision of section 98, 99 and 100 of the Act

All interested parties are hereby invited to make written representations as to why the registration should not be cancelled. **Only representations pertaining to this Notice will be considered. All correspondence should refer to case number: 2006/150.**

Objections must be lodged to me, c/o the Department of Labour, Laboria House, 215 Schoeman Street, PRETORIA. [Postal address: Private Bag X117, PRETORIA, 0001 – Fax No. (012) 309 4156 / 4595], within 60 days of the date of this notice.

J T CROUSE
REGISTRAR OF LABOUR RELATIONS

NOTICE 301 OF 2008

GENERAL NOTICE IN TERMS OF THE RESTITUTION OF LAND RIGHTS ACT, 1994 (ACT No. 22 OF 1994)

Notice is hereby given in terms of Section 11(1) of the Restitution of Land Rights Act, 1994 (Act No. 22 of 1994), as amended. These claims for the restitution of land rights have been submitted to the Regional Land Claims Commissioner for the Western Cape. The particulars regarding these claims are as follows:

Reference	Claimant	Property Description	Extent	Capacity	Deeds of Transfer	Current Owner	Date submitted
KRK6/2/3/A/1/0/1747/4 (R282)	GP Ronne	Erf 1012, Cape Town	7026m ²	Owner	T8130/69: T75780/96	Esposito J & P	17/12/1998
KRK6/2/3/A/1/0/331/83 (F59)	S Felix	Rem Erf 302, Cape Town	175m ²	Owner	T401/1882: T27159/96	Tradeprops 146 (Pty) LTD	13/05/1996
KRK6/2/3/A/1/0/331/137 (S193)	J Salie	Erf 311, Cape Town	100m ²	Owner	T4178/68: T23116/81	Joy Adele Lucas	07/05/1996
KRK6/2/3/A/6/2742/0/11 (N341)	J Nelson	N/A	N/A	Tenant	N/A		31/12/1998
KRK6/2/3/A/11/85/0/40 (L584)	EG Lesch	Erven 635,636,790,794 & 1819, Wellington	20m ² 555m ² 4083m ² 813m ² 97m ²	Owner	T28994/65: T11797/83 T408/61: T33671/80 T4952/66 T6224/42	Municipality of Wellington	04/11/1996
KRK6/2/3/A/7/68/0/14 (D789)	DD Davids	Erf 776, Somerset West	1329m ²	Owner	T21382/46: T308/74		30/11/1998
KRK6/2/3/A/10/82/0/275 (Z45)	CW Zwaan	Erf 9237, Northern Paarl	1215m ²	Owner	T7382/70: T18745/74	The Trustees of the Paarl Congregation of Jchovah's Witnesses	29/12/1998
KRK6/2/3/A/6/2742/0/552 (W312)	AL Williams	Erf 58682, Lansdowne	426m ²	Owner	T5031/71: T66418/91	Trust Kinonia	31/12/1998
KRK6/2/3/A/6/2742/0/70 (N57)	S Naidu	Erf 59374, Lansdowne	843m ²	Owner	T3993/46: T19951/74, T27256/99	Pragasen & Sharon Munien	29/07/1996
KRK6/2/3/A/6/2742/0/49 (A641)	DJ Adams	Erf 59397, Lansdowne	421m ²	Owner	T4216/45: T22668/74, T68762/89	Sheshagiri & Moganambal Dass	31/12/1998
KRK6/2/3/A/1/0/1368/13 (K267)	H Khan	Erf 23377, Maitland	8565m ²	Owner	T5022/69: T9115/74	Cape Suites (Pty) LTD	12/11/1996

NOTICE 302 OF 2008**DEPARTMENT OF LABOUR****LABOUR RELATIONS ACT, 1995****INTENTION TO CANCEL THE REGISTRATION OF A TRADE UNION**

I, Johannes Theodorus Crouse, Registrar of Labour Relations, hereby, in terms of section 106(2B) give notice of my intention to cancel the registration of **SOUTH AFRICAN FOOD AND ALLIED TRADE UNION (SAFATU) LR2/6/2/711** for the following reasons:

- the union has ceased to function as a genuine organisation as envisaged by the Act; and
- the union failed to comply with the provisions of 98, 99 and 100 of the Act.

All interested parties are hereby invited to make written representations as to why the registration should not be cancelled. **Only representations pertaining to this Notice will be considered. All correspondence should refer to case number: 2006/153.**

Objections must be lodged to me, c/o the Department of Labour, Laboria House, 215 Schoeman Street, PRETORIA. [Postal address: Private Bag X117, PRETORIA, 0001 – Fax No. (012) 309 4156 / 4595], within 60 days of the date of this notice.

J T CROUSE

REGISTRAR OF LABOUR RELATIONS

NOTICE 304 OF 2008**DEPARTMENT OF LABOUR****NOTICE PUBLISHED BY THE ESSENTIAL SERVICES COMMITTEE (the
'Committee')**

Under section 71 (8) of the Labour Relations Act, 1995 (Act No. 66 of 1995), the Essential Services Committee hereby gives notice that -

1. following services provided at all airports in South Africa have been designated as essential services:
 - (a) all **electrical** services;
 - (b) all **safety** services;
 - (c) all **security** services.

2. until the final designation is made.

Chairperson : Adv A. Mosam
ESSENTIAL SERVICES COMMITTEE

NOTICE 305 OF 2008
FINANCIAL SERVICES BOARD
NOTICE ON PROPOSED VARIATION OF
POLICYHOLDER PROTECTION RULES (SHORT-TERM INSURANCE), 2004

I, Robert James Gourley Barrow, Registrar of Short-term Insurance, after consultation with the Advisory Committee on Short-term Insurance, hereby under section 55(3) of the Short-term Insurance Act, 1998 (Act No. 53 of 1998), give notice of an intention-

- (a) to promulgate a variation of Rule 7.4 of the Policyholder Protection Rules (Short-term Insurance), as published by GN No. R. 1128 in *Gazette* No. 26853 of 30 September 2004 and set out in Schedule A;
- (b) to effect the variation of the Rule for the reasons and objects set out in the Memorandum of Reasons and Objects in Schedule B; and
- (c) to submit, under section 55(4) of the said Short-term Insurance Act, 1998, the proposed variation to the Rule, together with all written representations received, my comments and those of the said Advisory Committee, to the Minister of Finance for consideration and promulgation under section 55(5) of the said Act.

All interested persons are hereby invited to make representations, on the proposed Rule variation. All representations must be sent to the address below and must reach the Registrar within 30 days of publication of this Notice:

Attention: Ms M van Zyl
Financial Services Board
PO Box 35655
MENLO PARK
0102
Facsimile: (012) 347 1290
E-mail: meloniev@fsb.co.za

The Rules are available on the Financial Services Board's website at <http://www.fsb.co.za>.

R.J.G Barrow
REGISTRAR OF SHORT-TERM INSURANCE

SCHEDULE A

DEPARTMENT OF FINANCE

**VARIATION OF POLICYHOLDER PROTECTION RULES
(SHORT-TERM INSURANCE), 2004**

Section 55, Short-term Insurance Act, 1998

The Minister of Finance hereby under section 55(5) of the Short-term Insurance Act, 1998 (Act No. 53 of 1998), promulgates the variation of the Policyholder Protection Rules (Short-term Insurance, 2004), proposed by the Registrar of Short-term Insurance after consultation with the Advisory Committee on Short-term Insurance, as set out in the Schedule.

This Notice comes into operation on 1 September 2008.

T A Manuel, MP
Minister of Finance

SCHEDULE

VARIATION OF POLICYHOLDER PROTECTION RULES (SHORT-TERM INSURANCE), 2004

Section 55, Short-term Insurance Act, 1998

[Note: in this Schedule words in bold between brackets indicate deletions from, and words underlined indicate insertions in, the relevant existing enactment.]

Interpretation

1. In this Schedule "the Rules" means the Policyholder Protection Rules (Short-term Insurance), 2004, as published by GN No. R. 1128 in Gazette No. 26853 of 30 September 2004.

Variation of Rule 7.4

2 The following Rule is hereby substituted for Rule 7.4 of the Rules:

"Rejection of claims

7.4 (a) An insurance party involved [~~shall ensure that~~] must where [any] a decision [has been made as to the rejection] rejecting [of] any claim under a policy is made after 1 September 2008, or [as regards] where the quantum of a claim under a policy is in dispute after 1 September 2008 ensure, that the policyholder concerned is [In writing informed] notified, in writing, of the reasons for [the] such decision [and that the policyholder may within a period of not less than 90 days after the date of the relevant decision make representations to the relevant insurer in respect of such decision. The 90 days referred to may not be included in any time-barring period contained in the policy for the institution of legal action.]. The insurance party involved must, simultaneously with the above, notify the policyholder concerned in writing that the latter may, within 180 days of the date of the communication of the relevant decision, or such longer period as may be arranged for in the policy document,

- (i) make representations to the relevant insurer; or
- (ii) institute legal action,
regarding such decision.

- (b) If a claim is rejected or a quantum is disputed as contemplated in paragraph (a) on behalf of a short-term insurer by a person other than the short-term insurer, such other person must provide the [rejection] notice contemplated in that paragraph, provided that such [rejection] notice must also contain the name and contact details of the insurer and state that any recourse or enquiries must be directed directly to that insurer."

Short title

3. This Notice is called The Policyholder Protection Rules (Short-term Insurance) Variation Notice, 2008.

SCHEDULE B

MEMORANDUM OF REASONS FOR AND OBJECTS OF VARIATION OF RULE 7.4 OF THE POLICYHOLDER PROTECTION RULES (SHORT-TERM INSURANCE), 2004

Introductory

1. Rule 7.4(a) currently determines that the insurance party (insurer or intermediary) involved shall ensure that where a decision has been made as to the rejection of any claim under a policy or where the quantum of a claim is in dispute, the policyholder concerned must be informed of the reason for the decision in writing and that the policyholder has a period of not less than 90 days after the date of the relevant decision to make representations to the relevant insurer in respect of such a decision. The 90 days referred to above is in addition to any time-barring period contained in the policy for challenging the decision.

Reason

2. The main reason for proposing variations to Rule 7.4 of the Policyholder Protection Rules (PPRs) is based on specific comments that were made by some judges in a recent Constitutional Court case of B.P. Barkhuizen vs. R.S. Napier regarding the reasonableness and justifiability of the time-barring period for challenging the rejection of a claim.

Objective

3. If there was no provision for a time-barring clause in the Rules, the insured would, in terms of the Prescription Act have a period of three years from the date on which the debt becomes due to institute action against the insurer. The provisions of the Prescription Act were however, tempered by the introduction of a time-barring clause in the PPRs. The time-barring clause introduced in the PPRs had the effect of shortening the three years period to 90 days within which a policyholder has to issue a summons after the rejection of his/her claim by an insurer or when he/she is not in agreement with the quantum of the claim.

4. The rationale for the introduction of the time-barring period in the PPRs was to ensure that claims come to the attention of insurers speedily and that insurers have the advantage of recency to be able to investigate the circumstances leading to the claim. One example of a consequence of not acting speedily could be that evidence can become unavailable or that an essential witness becomes unavailable or forgets the circumstances relating to the claim. However, the counter argument to the above is that while the need for acting speedily certainty is clearly important, the consequences of failing to claim timeously could be to the detriment of the insured. The proposed 180 days time-barring period is an attempt to be fair and reasonable to both insurers and insured persons.

5. As far as the nature and extent of the limitation is concerned, the time-barring period for challenging the rejection of a claim or disputing the quantum of a claim, involves a far-reaching and drastic protection of the insurer to the detriment of the insured. The challenge was for the regulator to decide whether to take action to address this matter.

Decision

6. After lengthy deliberations with the industry representative body and consultations with the Short-term Insurance Advisory Committee it was agreed that the current minimum requirement of a 90 days time-barring period be replaced with a minimum 180 days time-barring period to challenge the rejection of a claim or dispute the quantum of a claim.

Commencement

7. It is currently expected that the so varied Rule 7.4 will come into operation on 1 September 2008.

NOTICE 286 OF 2008

CO-OPERATIVES TO BE STRUCK OFF THE REGISTER: NCEDISIZWE POULTRY CO-OPERATIVE LIMITED; THULA-DU POULTRY REARING CO-OPERATIVE LIMITED; THUBALETHU MANUFACTURING CO-OPERATIVE LIMITED; THUBELIHLE CO-OPERATIVE LIMITED; THUBALETHU CO-OPERATIVE LIMITED; THUBALETHU COMMERCIAL FARMERS CO-OPERATIVE LIMITED; BONXA COMMUNAL CO-OPERATIVE ASSOCIATION LIMITED; NCEDANANI SEWING PROJECT CO-OPERATIVE LIMITED; NCASAZA COMMUNITY GARDEN CO-OPERATIVE LIMITED; BONTLE BAKERY CONFECTIONERY AND CATERING CO-OPERATIVE LIMITED; THOKOZA CO-OPERATIVE LIMITED AND THOKOZADLOZI CO-OPERATIVE LIMITED

Notice is hereby given that the names of the above-mentioned co-operatives will, after the expiration of sixty (60) days from the date of this notice, be struck off the register in terms of the provisions of section 73 (1) of the Co-operatives Act, 2005, and the co-operatives will be dissolved unless proof is furnished to the effect that the co-operatives are carrying on business or are in operation.

Any objections to this procedure, which interested persons may wish to raise, must together with the reasons therefor, be lodged with this office before the expiration of the period of sixty (60) days.

Registrar of Co-operatives

Office of the Registrar of Co-operatives
DTI Campus
77 Meintjies Street
Private Bag X237
PRETORIA
0001

KENNISGEWING 286 VAN 2008

KOÖPERASIES VAN DIE REGISTER GESKRAP TE WORD: NCEDISIZWE POULTRY CO-OPERATIVE LIMITED; THULA-DU POULTRY REARING CO-OPERATIVE LIMITED; THUBALETHU MANUFACTURING CO-OPERATIVE LIMITED; THUBELIHLE CO-OPERATIVE LIMITED; THUBALETHU CO-OPERATIVE LIMITED; THUBALETHU COMMERCIAL FARMERS CO-OPERATIVE LIMITED; BONXA COMMUNAL CO-OPERATIVE ASSOCIATION LIMITED; NCEDANANI SEWING PROJECT CO-OPERATIVE LIMITED; NCASAZA COMMUNITY GARDEN CO-OPERATIVE LIMITED; BONTLE BAKERY CONFECTIONERY AND CATERING CO-OPERATIVE LIMITED; THOKOZA CO-OPERATIVE LIMITED EN THOKOZADLOZI CO-OPERATIVE LIMITED

Hiermee word bekendgemaak dat die name van bogenoemde koöperasies na verloop van sestig (60) dae met ingang vanaf die datum van hierdie kennisgewing van die register geskrap sal word ooreenkomstig die bepalings van artikel 73 (1) van die Koöperasiewet, 2005, die die koöperasies sal ontbind word tensy bewys gelewer word dat die koöperasies handel drywe of in werking is.

Enige besware wat belanghebbende persone teen hierdie prosedure wil inbring, moet met vermelding van redes voor verstryking van die tydperk van sestig (60) dae by hierdie kantoor ingedien word.

Registrateur van Koöperasies

Kantoor van die Registrateur van Koöperasies
DTI Kampus
Meintjiesstraat 77
Privaatsak X237
PRETORIA
0001

(29 February 2008)/(29 Februarie 2008)

NOTICE 287 OF 2008

CO-OPERATIVES TO BE STRUCK OFF THE REGISTER: THOLIMPILO CO-OPERATIVE LIMITED; BHEK' EKHAYA AGRICULTURAL CO-OPERATIVE LIMITED; NCEDISIZWE DEVELOPMENT CO-OPERATIVE LIMITED; THOBELANI BAKING CO-OPERATIVE LIMITED; PHAKAMANI POULTRY CO-OPERATIVE LIMITED; THULA UBHEKE SEWING CO-OPERATIVE LIMITED; THOLILE PAINTINGS, RENOVATIONS AND CLEANING CO-OPERATIVE LIMITED; THOKOLA THEMBA CO-OPERATIVE LIMITED; THOHYANDOU SAVINGS AND CREDIT CO-OPERATIVE LIMITED; THOLE DISTRIBUTORS CO-OPERATIVE LIMITED; THORNHILL STATIONERY SUPPLIERS CO-OPERATIVE LIMITED; THULA-DU CO-OPERATIVE LIMITED; PHAKAMANI BALIMI CO-OPERATIVE LIMITED; PEOPLE'S ALIVE CO-OPERATIVE LIMITED AND PENHILL RESIDENTS SMALL FARMERS CO-OPERATIVE LIMITED

Notice is hereby given that the names of the above-mentioned co-operatives will, after the expiration of sixty (60) days from the date of this notice, be struck off the register in terms of the provisions of section 73 (1) of the Co-operatives Act, 2005, and the co-operatives will be dissolved unless proof is furnished to the effect that the co-operatives are carrying on business or are in operation.

Any objections to this procedure, which interested persons may wish to raise, must together with the reasons therefor, be lodged with this office before the expiration of the period of sixty (60) days.

Registrar of Co-operatives

Office of the Registrar of Co-operatives
DTI Campus
77 Meintjies Street
Private Bag X237
PRETORIA
0001

KENNISGEWING 287 VAN 2008

KOÖPERASIES VAN DIE REGISTER GESKRAP TE WORD: THOLIMPILO CO-OPERATIVE LIMITED; BHEK' EKHAYA AGRICULTURAL CO-OPERATIVE LIMITED; NCEDISIZWE DEVELOPMENT CO-OPERATIVE LIMITED; THOBELANI BAKING CO-OPERATIVE LIMITED; PHAKAMANI POULTRY CO-OPERATIVE LIMITED; THULA UBHEKE SEWING CO-OPERATIVE LIMITED; THOLILE PAINTINGS, RENOVATIONS AND CLEANING CO-OPERATIVE LIMITED; THOKOLA THEMBA CO-OPERATIVE LIMITED; THOHOYANDOU SAVINGS AND CREDIT CO-OPERATIVE LIMITED; THOLE DISTRIBUTORS CO-OPERATIVE LIMITED; THORNHILL STATIONERY SUPPLIERS CO-OPERATIVE LIMITED; THULA-DU CO-OPERATIVE LIMITED; PHAKAMANI BALIMI CO-OPERATIVE LIMITED; PEOPLE'S ALIVE CO-OPERATIVE LIMITED EN PENHILL RESIDENTS SMALL FARMERS CO-OPERATIVE LIMITED

Hiermee word bekendgemaak dat die name van bogenoemde koöperasies na verloop van sestig (60) dae met ingang vanaf die datum van hierdie kennisgewing van die register geskrap sal word ooreenkomstig die bepalings van artikel 73 (1) van die Koöperasiewet, 2005, die die koöperasies sal ontbind word tensy bewys gelewer word dat die koöperasies handel drywe of in werking is.

Enige besware wat belanghebbende persone teen hierdie prosedure wil inbring, moet met vermelding van redes voor verstryking van die tydperk van sestig (60) dae by hierdie kantoor ingedien word.

Registrateur van Koöperasies

Kantoor van die Registrateur van Koöperasies
DTI Kampus
Meintjiesstraat 77
Privaatsak X237
PRETORIA
0001

(29 February 2008)/(29 Februarie 2008)

NOTICE 288 OF 2008

CO-OPERATIVES REMOVED FROM REGISTER: LWALWENI FARMERS ASSOCIATION CO-OPERATIVE LIMITED; LEHUMO LE TSWA TSHEMONG AGRICULTURAL CO-OPERATIVE LIMITED; LENTULE FAMINI WOOLGROWERS CO-OPERATIVE LIMITED; VUKAMAWULELE POULTRY CO-OPERATIVE LIMITED; LANGANANI FARMERS AGRICULTURAL CO-OPERATIVE LIMITED; KOLONTOANE PRIMARY AGRICULTURAL CO-OPERATIVE LIMITED; VLK (KOÖPERATIEF) BEPERK; KWA WOZA CO-OPERATIVE LIMITED; LIVESTOCK AND MEAT CO-OPERATIVE ENTERPRISE LIMITED; K.M.N.C. FARMERS CO-OPERATIVE LIMITED; KITLANO CO-OPERATIVE LIMITED; KHAPHUZELA POULTRY CO-OPERATIVE LIMITED AND KZN PAPER MAKING AND CRAFT PACKAGING CO-OPERATIVE LIMITED

Notice is hereby given that the names of the above-mentioned co-operatives were removed from the register on 1 February 2007 in terms of section 73 (1) (c) of the Co-operatives Act, 2005.

Registrar of Co-operatives

KENNISGEWING 288 VAN 2008

KOÖPERASIES WAT VAN DIE REGISTER GESKRAP IS: LWALWENI FARMERS ASSOCIATION CO-OPERATIVE LIMITED; LEHUMO LE TSWA TSEMONG AGRICULTURAL CO-OPERATIVE LIMITED; LENTULE FAMINI WOOLGROWERS CO-OPERATIVE LIMITED; VUKAMAWULELE POULTRY CO-OPERATIVE LIMITED; LANGANANI FARMERS AGRICULTURAL CO-OPERATIVE LIMITED; KOLONTOANE PRIMARY AGRICULTURAL CO-OPERATIVE LIMITED; VLK (KOÖPERATIEF) BEPERK; KWA WOZA CO-OPERATIVE LIMITED; LIVESTOCK AND MEAT CO-OPERATIVE ENTERPRISE LIMITED; K.M.N.C. FARMERS CO-OPERATIVE LIMITED; KITLANO CO-OPERATIVE LIMITED; KHAPHUZELA POULTRY CO-OPERATIVE LIMITED AND KZN PAPER MAKING EN CRAFT PACKAGING CO-OPERATIVE LIMITED

Hiermee word bekendgemaak dat die name van bogenoemde koöperasies op 1 Februarie 2007 ingevolge die bepalings van artikel 73 (1) (c) van die Koöperasiewet, 2005, van die register geskrap is.

Registrateur van Koöperasies

(29 February 2008)/(29 Februarie 2008)

NOTICE 289 OF 2008

CO-OPERATIVES TO BE STRUCK OFF THE REGISTER: XOLANI MAWETHU POULTRY CO-OPERATIVE LIMITED; NTINGA SKOLWENI FARMERS CO-OPERATIVE LIMITED; THE KINGFISHER'S CO-OPERATIVE LIMITED; THEMBALABO POULTRY PROJECT CO-OPERATIVE LIMITED; THEMBALETHU SAVINGS & CREDIT CO-OPERATIVE LIMITED; TEXAS VALLEY DEVELOPMENT CO-OPERATIVE LIMITED; THABA-NCHU FINANCIAL SERVICES CO-OPERATIVE LIMITED; THEMBALETHU TRANSPORT CO-OPERATIVE LIMITED; THEMBEKA CO-OPERATIVE LIMITED; THEMBELIHLE TRADING CO-OPERATIVE LIMITED; THEMBELANI WOMEN'S CO-OPERATIVE LIMITED; THEMBEKHAYA TRADING MARKET CO-OPERATIVE LIMITED AND XAKEKA FRUIT AND VEGETABLE CO-OPERATIVE LIMITED

Notice is hereby given that the names of the above-mentioned co-operatives will, after the expiration of sixty (60) days from the date of this notice, be struck off the register in terms of the provisions of section 73 (1) of the Co-operatives Act, 2005, and the co-operatives will be dissolved unless proof is furnished to the effect that the co-operatives are carrying on business or are in operation.

Any objections to this procedure, which interested persons may wish to raise, must together with the reasons therefor, be lodged with this office before the expiration of the period of sixty (60) days.

Registrar of Co-operatives

Office of the Registrar of Co-operatives
DTI Campus
77 Meintjies Street
Private Bag X237
PRETORIA
0001

KENNISGEWING 289 VAN 2008

KOÖPERASIES VAN DIE REGISTER GESKRAP TE WORD: XOLANI MAWETHU POULTRY CO-OPERATIVE LIMITED; NTINGA SKOLWENI FARMERS CO-OPERATIVE LIMITED; THE KINGFISHER'S CO-OPERATIVE LIMITED; THEMBALABO POULTRY PROJECT CO-OPERATIVE LIMITED; THEMBALETHU SAVINGS & CREDIT CO-OPERATIVE LIMITED; TEXAS VALLEY DEVELOPMENT CO-OPERATIVE LIMITED; THABA-NCHU FINANCIAL SERVICES CO-OPERATIVE LIMITED; THEMBALETHU TRANSPORT CO-OPERATIVE LIMITED; THEMBEKA CO-OPERATIVE LIMITED; THEMBELIHLE TRADING CO-OPERATIVE LIMITED; THEMBELANI WOMEN'S CO-OPERATIVE LIMITED; THEMBEKHAYA TRADING MARKET CO-OPERATIVE LIMITED EN XAKEKA FRUIT EN VEGETABLE CO-OPERATIVE LIMITED

Hiermee word bekendgemaak dat die name van bogenoemde koöperasies na verloop van sesstig (60) dae met ingang vanaf die datum van hierdie kennisgewing van die register geskrap sal word ooreenkomstig die bepalings van artikel 73 (1) van die Koöperasiewet, 2005, die die koöperasies sal ontbind word tensy bewys gelewer word dat die koöperasies handel drywe of in werking is.

Enige besware wat belanghebbende persone teen hierdie prosedure wil inbring, moet met vermelding van redes voor verstryking van die tydperk van sestig (60) dae by hierdie kantoor ingedien word.

Registrateur van Koöperasies

Kantoor van die Registrateur van Koöperasies
DTI Kampus
Meintjiesstraat 77
Privaatsak X237
PRETORIA
0001

(29 February 2008)/(29 Februarie 2008)

NOTICE 290 OF 2008

CO-OPERATIVES TO BE STRUCK OFF THE REGISTER: XIHLUKE SOCIAL SERVICE CO-OPERATIVE LIMITED; XHASA FARMER SUPPLY CO-OPERATIVE LIMITED; YAKHANATHI HEALTH CARE CO-OPERATIVE LIMITED; THATHUNYANO AGRICULTURAL DEVELOPMENT CO-OPERATIVE LIMITED; NOMZAMO CROP PRODUCTION CO-OPERATIVE LIMITED; NTOBOZI AGRICULTURAL CO-OPERATIVE LIMITED; THAND' UXOLO CO-OPERATIVE LIMITED; XHIFIMI FARMERS CO-OPERATIVE LIMITED; XHAMLANI GROUND NUTS CO-OPERATIVE LIMITED; PENDU MAIZE CO-OPERATIVE LIMITED AND PENDU FRUIT AND VEGETABLE CO-OPERATIVE LIMITED

Notice is hereby given that the names of the above-mentioned co-operatives will, after the expiration of sixty (60) days from the date of this notice, be struck off the register in terms of the provisions of section 73 (1) of the Co-operatives Act, 2005, and the co-operatives will be dissolved unless proof is furnished to the effect that the co-operatives are carrying on business or are in operation.

Any objections to this procedure, which interested persons may wish to raise, must together with the reasons therefor, be lodged with this office before the expiration of the period of sixty (60) days.

Registrar of Co-operatives

Office of the Registrar of Co-operatives
DTI Campus
77 Meintjies Street
Private Bag X237
PRETORIA
0001

KENNISGEWING 290 VAN 2008

KOÖPERASIES VAN DIE REGISTER GESKRAP TE WORD: XIHLUKE SOCIAL SERVICE CO-OPERATIVE LIMITED; XHASA FARMER SUPPLY CO-OPERATIVE LIMITED; YAKHANATHI HEALTH CARE CO-OPERATIVE LIMITED; THATHUNYANO AGRICULTURAL DEVELOPMENT CO-OPERATIVE LIMITED; NOMZAMO CROP PRODUCTION CO-OPERATIVE LIMITED; NTOBOZI AGRICULTURAL CO-OPERATIVE LIMITED; THAND' UXOLO CO-OPERATIVE LIMITED; XHIFIMI FARMERS CO-OPERATIVE LIMITED; XHAMLANI GROUND NUTS CO-OPERATIVE LIMITED; PENDU MAIZE CO-OPERATIVE LIMITED EN PENDU FRUIT EN VEGETABLE CO-OPERATIVE LIMITED

Hiermee word bekendgemaak dat die name van bogenoemde koöperasies na verloop van sestig (60) dae met ingang vanaf die datum van hierdie kennisgewing van die register geskrap sal word ooreenkomstig die bepalings van artikel 73 (1) van die Koöperasiewet, 2005, die die koöperasies sal ontbind word tensy bewys gelewer word dat die koöperasies handel drywe of in werking is.

Enige besware wat belanghebbende persone teen hierdie prosedure wil inbring, moet met vermelding van redes voor verstryking van die tydperk van sestig (60) dae by hierdie kantoor ingedien word.

Registrateur van Koöperasies

Kantoor van die Registrateur van Koöperasies
DTI Kampus
Meintjiesstraat 77
Privaatsak X237
PRETORIA
0001

(29 February 2008)/(29 Februarie 2008)

NOTICE 303 OF 2008

DEPARTMENT OF LABOUR

LABOUR RELATIONS ACT, 1995

REGISTRATION OF A TRADE UNION

I, Johannes Theodorus Crouse, Registrar of Labour Relations, hereby notify, in terms of section 109 (2) of the Labour Relations Act, 1995, that **South African Emergency Personnel's Union (SAEPU)** has been registered as a trade union with effect from 19 February 2008.

J. T. CROUSE

Registrar of Labour Relations

(29 February 2008)
